

107?

DIAMOND DOUBLE DISCS.

PLAYS WITH A JEWEL.

PRACTICALLY
UNWEARABLE.

TRADE



MARK.

REGISTERED.

ONE
SIZE
10½-In.



DIAMOND
DISCS are
stocked by all
good Dealers.

Ask your Dealer
for Latest Lists.

Abolishes Needles.

ONE PRICE,

1/6



Fits any
Gramophone
instantly
without alteration,

3/6 RETAIL.

WRITE FOR OUR SPECIAL NEW LIST OF TITLES.

If any difficulty in obtaining supplies write to

DIAMOND DISC RECORD, Ltd., 81, City Road, LONDON, E.C.

THE HILLANDALE JUBILEE ISSUE NEWS

April 1919

ALL THE WORLD CAN BE AMUSED.

All the world knows what a welcome addition an Edison Phonograph is to the family circle—especially during the long winter evenings now rapidly approaching.

But few know what an immense improvement the EDISON AMBEROLA III. is over the usual type of sound reproducing machines.

This wonderful instrument reproduces the pure tone of instrumental and vocal music with



exceptional clearness, charm and beauty. All the slightest variations of vocalisation are faithfully and truthfully reproduced. With the EDISON AMBEROLA III. (as with other EDISON PHONOGRAPHS), there is no accompaniment of buzzing and scratching noises.

The AMBEROLA III. is absolutely flawless and cannot be approached by any other instrument for musical quality.

AMBEROLA III.

The NEWEST EDISON PHONOGRAPH, is
the BEST ENTERTAINER for Winter Evenings.

Go to an Edison Dealer, he
will tell you all about it.

Thomas A Edison Ltd. WILLESDEN JUNCTION,
LONDON, - - N.W.

From "Sound Wave", October 1912

Chairman's Chat

Anyone who has been a member of this Society for only two or three years might be excused for thinking that we seem to be forever celebrating anniversaries. We had the Centenary in 1977, followed almost at once by the 100th *Hillandale News*, and now, here we are again, celebrating our Diamond Jubilee!

Yes, the Society was formed in May 1919, and our sixtieth birthday is upon us. Would that I could look back and reminisce on the activities of those sixty years – but alas!, I am only a newcomer, an upstart, and a collector of those accursed (I curse them every time I stub my toe on one . . .) lateral-cut gramophones which our founders despised. Do not misunderstand me; I would be the first to admire the design and the workmanship of the Edison phonograph – but oh, the drivel on so many of those cylinders! Now, if Nikisch had recorded the Beethoven Fifth on Blue Amberols in 1912, and Toscanini again in 1929, how much more often I would play a phonograph!

That, however, is merely a personal aside. I think we should not be afraid to blow our trumpets a bit, for sixty years is no mean achievement for a society of this type. There have been ups and downs, but at present things are very much 'up'. Membership is increasing healthily (this is always desirable, as the relative cost-per-copy of the magazine decreases as the number of members rises), and the Treasurer and the Vice-Chairman are working very hard to expand and improve the spares and publications services respectively.

It is worth mentioning here, I think, that the Society is run entirely by volunteers working in their spare time. The total number of hours put in on our behalf by Officers, Committee members and others over the years must be colossal. This is a tribute therefore, to all such volunteers, past and present, who have kept the Society going through thick and thin. Let me also give them an exhortation for the future – Keep up the good work!

* * * * *

From the general to the particular: I regret to have to say that Bill Brott, who has been unwell for some time, has decided that he cannot carry on with his work for the *Hillandale News*. I hope that when he is restored to full health we may be able to call on him again, particularly for his skills in designing headings and 'Special Issue' front covers; in the meantime, I would like to express my thanks for all his work in the past, and to wish him a speedy recovery.

AN APOLOGY

On the centre pages of our December 1978 issue, we reproduced one side of a Columbia leaflet illustrating their range of machines for 1929. The accompanying caption (on Page 161) referred, tantalisingly, to both sides of the leaflet, but a 'hiccup' in the new Editorial system prevented the back from being printed. Because of the way the original was intended to fold, part of the reverse is printed upside-down, so that it does not make a centre-page spread as the first side did, but we have re-assembled the various panels from the reverse side on the centre pages in this issue. Our apologies to those who have been searching in vain for an explanation of Plano-Reflex!

Sixty Years Ago

To recall the foundation of our Society sixty years ago, in May 1919, we print below a series of letters which appeared at that time in **The Talking Machine News and Sound Wave**.

PROPOSED LONDON EDISON SOCIETY

Dear Sir, —Manchester can boast of an Edison Society, and an exceptionally successful society it is, too, judging from the number of its members and their unabated enthusiasm. Why should the capital of these Isles lag behind the famous Lancashire city. "Three Edisonites" would like to know? and would like to meet other Edisonites piqued with a similar touch of curiosity and fired with a desire to remedy such a state of affairs. Assuming that this letter will draw sufficient response to warrant the formation of an Edison Society, the above referred to "Three Edisonites" would like to make the following preliminary proposals:—

- (1) That the suggested new Society be called "The London Edison Society."
- (2) That the headquarters be as central as possible (i.e. E.C. or W.C.) so as to draw Edison enthusiasts from all parts of the Metropolis.
- (3) That the meetings be held on the first Saturday in each month, or on a Wednesday or Thursday, so as not to clash with the meetings of the existing London Gramophone, etc., societies, and commence at 7 p.m. sharp.
- (4) That the annual subscription be 5s., and that the rules—so far as they can be made to apply to an Edison Society—be the same as those printed in extenso in that excellent article which appeared in the January edition of the "Sound Wave" entitled "The Evolution of the Society."

Trusting that you will be so good as to publish this.—We are, dear sir, yours truly,

"THREE EDISONITES"

43 Baalbec Road, N.5., February 3, 1919.

PS —Will those interested please communicate in the first onset with Mr. J.W. Crawley, 27, Horsham Avenue, N.12?

(We cordially commend the formation of a Central London Edison Society, and trust that it will mature. The more societies the better, as we know of no better medium of inter-communication between talking-machine devotees than the Society. Our correspondent will notice that in the current issue we have allocated a special column for Society movements, and any further communications anent same should be addressed to 'Pertinax'.

The "Letter Box" column will continue, as usual, but matters treated in this column are primarily those connected with technical difficulties and queries of a more general character. —Ed.)

To the Editor of THE TALKING MACHINE NEWS

Sir, —Mr. Sanders' letter on the Future of the Cylinder is, unhappily, only too true. The devotees of the cylinder are indeed in a bad way, but I think I am right in saying that the Edison Company do not intend to altogether desert the British enthusiast, and may in due course set up again on our side. I have been asked to join the committee of the proposed London Edison Society referred to in the March issue, and we are out to achieve all we can for cylinder users, of whom, as Mr. Sanders says, there are thousands. Several enthusiasts besides myself have written from time to time complaining of the trash we get on Blues, and our watchword will be, "British artists and good music for British people." and it is for this reason that I venture to ask support for the London Edison Society.

I am, yours truly,
C.R.W. MILES

1, Portland Villas, East Heath Road,
Hampstead, London N.W.3.

A VOICE FROM HAMPSTEAD

Mr. C.R.W. Miles, well known as an old Edisonian enthusiast, congratulates the Editor on the new feature of the Societies' column. "All enthusiasts", he writes, "should, if possible, join societies, or, if they have not one available to belong to, try to form one. The latest recruit is the proposed "London Edison Society", referred to in the correspondence of your March number. I hope to be able to act on the committee, and we shall adopt a progressive policy—better music, British bands, artists, songs, and generally further the interests of cylinder users all over the country. I should not advise anyone who possesses 'O' Repros, Cygnet, and good machines to part with them, as we have every reason to hope for better

things to come. One new feature now being introduced on the 'Blues' in America is the whole uncut version of selections like Overtures, etc., complete on two or more cylinders."

Mr. J.W. Crawley (Finchley) writes:—"I was very much interested in reading your excellent column in the March "Sound Wave", and consider we Society people are fortunate in having an expert to look after our interests. With regard to the London Edison Society, you will no doubt be interested to learn that more than a score gentlemen have promised to join, so there is no doubt the Society will be formed in due course. Further particulars later."

THE BLUES!

The suggestion of an Edison Society for London is meeting with approval from all quarters, so it seems. A letter from Mr. A.C. Harwood, of 371, London Road, Westcliff-on-Sea, has been handed to me by the Editor, and here it is: "Dear Sir,—The idea mooted in your last issue by "Three Edison-ites" for the formation of an all Edison Society, with headquarters in the W.C. or E.C. districts, is most excellent, as there must be many enthusiasts of this cult of sound-reproduction who would welcome with open arms, so to speak, an opportunity for exchange of views and the smoothing away of little difficulties that are bound to arise. Any assistance within my power I shall be happy to give, and I trust the day will not be far distant when the new Society will be able to hold its first meeting; in fact, I am already looking forward to a very pleasant First Night and a demonstration of some fine 'Blues'.

LONDON EDISON SOCIETY

Mr. W.J. Crawley writes that the above Society has been formed, and that the first general meeting will take place on Wednesday, May 28, at 7 p.m., at "The Clachan," Mitre Court, Fleet Street, E.C. All cylinderites are cordially invited and some new "Royal Purple" Amberols will be demonstrated.

To the Editor of THE TALKING MACHINE NEWS

Dear Sir,—(1) With reference to the various letters which have appeared in your columns regarding the formation of a London Edison Society, I have pleasure in advising you that the response from

Edison enthusiasts has been so encouraging that the London Edison Society is now an accomplished fact. The Society starts its career with a membership of thirty, and the first general meeting will be held on Wednesday evening, May 28th, at "Clachan," Mitre Court, Fleet Street, E.C., at 7 o' clock.

(2) A hearty invitation is extended to all interested to attend the first meeting, when it is hoped we shall be able to demonstrate some of the new "Royal Purples" and "Blue Amberols" records. Further particulars of the Society will be gladly furnished by the undersigned.

Yours faithfully,
J.W. CRAWLEY

27 Horsham Avenue, London, N.12.
April 23rd, 1919.

THE NEW EDISON SOCIETY

The new society started off in good form, about fifty enthusiasts being present during the evening, as far as I was able to keep count, between sundry glasses of the best beer I have tasted since the Government ale took the place of the apothecary. The chairman, Mr. N.R. Hillyer (who, I hear, is still remaining as active as ever as secretary to the North London Society) introduced some specimens of the new Purple Amberols—the latest product of the Edison laboratory, which were really better than I expected them to be, judging from their previous reception at the North London. Of course, everyone knows that the North London is exceptionally critical on fine points, but I think the new records bear comparison with the old, at least. Possibly a different machine makes a difference. Anyhow, after one or two amendments had been put, but lost, the rules as drafted were carried, and future meetings are to be held at the Food Reform Restaurant, Furnival Street, E.C.

THOSE IMPORT RESTRICTIONS

It is gratifying to learn that the import restrictions for talking machines, etc., have at last been removed, although nothing has yet been said about abolishing Tariff Reform. The duty of 33 per cent. will be a serious barrier on Edison goods, which are being awaited with much anticipated pleasure by a considerable section of the British public. The "Blue Amberols" are likely to have a new boom, and Edison discs are also in good demand.

Vice Chairman's Chat

I have now settled into my new role as Vice chairman, and am finding that I am well loaded with work. Apart from handling the advertising which brings in quite a large amount of mail I have taken the task of distribution of the reprints etc. The local post office is getting used to seeing me arrive with a bag full of letters which all have to be weighed separately because of the differing content. They have not got to the stage where they close as I arrive but they argue about who is going to serve me. For those who have previously experienced delays on deliveries for no apparent reason or with no explanation you will find that we are enjoying a very fast turn round of orders when the orders are made out correctly with the correct money included. We are still enlarging the spares and reprint list and when we are settled we will issue a respectable list which will be comprehensive with a range second to none.

The almanac is still being produced with difficulty owing to non-communication from various sources or late information.

By the time this magazine reaches you plans will be well advanced for our Diamond Dinner Date on the 18th of May. If you have not got your invitation yet you should get on to the Secretary rapidly with your money in hand. It should turn out to be a memorable evening with many well known names in the Gramophone world.

I think I had better move off the page before the Chairman complains that I have more than my share of the chat column.

The Editor
Hillandale News

11 January 1979

REALISM IN ACOUSTIC REPRODUCTION

Sir,

In order to share with others the collection of over 20 machines that my wife and I have rescued and restored, we sometimes demonstrate them at Steam Rallies, Parties, etc, and find many people are interested in hearing them.

The enclosed photograph shows a Zonophone which has a rather odd tone arm fitted with a Columbia soundbox (with metal diaphragm) this gives very good results and is loud enough for use out of doors. The other machine is a replica Berliner that I built for demonstration purposes, it plays 7" 'Victory' records quite well, with a sound not unlike a small phonograph, such as our Pathe 'Coq'.

We find the best reproduction of all is given by our HMV 163 'Re-entrant', when the record played is electrically recorded, whereas acoustic recordings often sound better when played on the 'Zonophone'.

We have recently been struck by the remarks of people who have never heard an acoustic machine perform, before listening to ours. Remarks such as 'it sounds real' and 'I can pick out all the instruments, it is very clear' and 'although the bass is not as good (as an LP played electrically) the treble is marvellous' are quite typical.

As if this were not sufficient, our cat, who seems sometimes to be listening to the music, tonight astonished me when a rather husky voiced part of one of our records sung by Marion Harris ('If I could be with you' Brunswick 4873) caused her to leap from her slumbers into a defensive attitude. She was not going to have this other female hissing at her! I repeated this experiment twice more with similar results, she did not realise even then that it was only a gramophone, which surprised me, as our cat is not easily fooled by such things as a rule.

Other collectors will be familiar with 'forward' records and 'presence', qualities not usually found in modern records played electrically, to the extent found in some 78s.



A Hi-Fi enthusiast friend who has heard our model 163 says his equipment sounds 'flat' by comparison, but that this is overcome in the most expensive equipment, which is beyond the reach of most people.

For my part, I feel there is a greater illusion of reality (especially with records of solo instruments) given by a good acoustic machine than our own 'record player'.

All of which leads me to wonder if there is something the old shellac discs have, or acoustic machines can do, that we have lost in our progressive, technological leaps, that would bear investigation.

Perhaps some other society members can suggest the reasons for these phenomena, or tell me why Caruso never sounds quite the same if he is not booming out of an external horn machine?

John Bourne

Note from the Editor: The Zonophone had me puzzled when I first saw the photograph, for there seemed to be several features that looked 'wrong'. Apart from the soundbox and the front part of the tone-arm (Columbia, c. 1930), the brake is a continental type, the back-bracket looks unorthodox where the elbow fits, the usual Zonophone circular transfer is missing from the front, and the winder looks Garrard-ish. I therefore wrote to Mr. Bourne and elicited some further details: the transfer is on the side, the motor is Gramophone Co., circa 1920 (as it should be) and the elbow is a modern cast aluminium reproduction. There is no sign of any redundant screw-holes, and the back-bracket seems to fit correctly. The fact remains that Gramophone Co. back brackets at this time had a deep socket at the top, **into** which the elbow fitted. As for the brake, I have never yet found evidence of the Hayes factory using bought-in components (apart from cabinet fittings) before the 1930s. (Remember, they even imported and converted their own timber!) Of course, I have only seen the photograph; were I to see the machine itself, all might fall into place!

Soundboxes

AN ADDENDUM TO THE NOTES ON pp 120-121 (HILLANDALE No.104, OCTOBER 1978)

From Jim Goodall comes the following comments:

BARCROLE I would like to thank the writer of 'Soundboxes' for his description of the array of soundboxes on the front cover of the April 1978 issue. I was particularly intrigued by the Barcrole with its double stylus and apparent two diaphragms, the second of which appears to be suspended free over the front of the soundbox. I would have thought that the added mass and inertia would have made it more difficult to balance for accurate tracking, thus increasing surface chatter and consequent record wear . . .

DUOPHONE In a visit to London last year, I saw in an antique shop a gramophone with two soundboxes whose mica diaphragms were connected to the two forks of a common stylus, one fork being longer than the other. Unfortunately, I could not get near enough to see how it worked. I live in hopes that in the course of my membership of the C.L.P.G.S. I may be privileged to hear one of these machines in action.

TREMUSA Only a week ago, I came across a Tremusa soundbox on an old H.M.V. pedestal gramophone I was overhauling for a friend. It was exactly as described in October's Hillandale, save that in place of the whalebone tension springs, two pieces of flat governor-spring were held in place across slots in the stylus crossbar. Embossed in copperplate on top of the outside perimeter were the words 'The Three Muses - Patented'. There were no other identification marks. The performance was very good.

. . . and

MAINSPRINGS Incidentally, the gramophone had a triple-spring motor, the three springs being contained in separate drums on a common spindle. The springs would be at least $\frac{3}{4}$ " wide (actually 1" -Ed.) by 12½ft. long and the drum covers were dead flush with the rims, as if they had been sealed on by contraction. Fortunately, all that was needed was oil, but had a spring been broken, it would have been a wicked job to open one of those drums.

From the Editor, these in reply:

Although the Barcrole appears to have two diaphragms, study of the original advertisements suggests that this is not so. The 'free' object in front of the soundbox, which was not very clear in the illustration, is a conical shape formed in the aluminium body, apparently intended to diffuse sound from the front of the diaphragm, like the auxiliary horn on the Pixie Grippa.

According to the Talking Machine News of November 1924 (copying a manufacturer's press release, no doubt) this conical device was fitted 'To prevent wastage of energy'. The Barcole was available in aluminium with an aluminium diaphragm, or in ebonite with a mica diaphragm.

The machine in the antique shop was clearly a Duophone. This had one soundbox behind the other, with stylus-bars of different length and one mica thicker than the other. The idea was that one took care of the treble and the other of the bass.

I have never heard of a Three Muses or Tremusa soundbox in contemporary references except as having whalebone springs, but it could well be that this was an early one. However, the system of mounting is exactly the same, and I suspect that someone has replaced the original whalebone in this case — beneficially, I dare say.

The covers on early H.M.V. spring-drums (these would be about 1920) are a press-fit, and can be removed by 'springing' out. In some instances, where the spring-arbor projects below the bottom of the drum and is prevented from moving upwards only by the cover, you simply bring it down hard on the workbench (not the dining-room table) to force the cover out. Otherwise, a large drift can be inserted from the bottom and tilted slightly to one side of the hole in the cover. If more than one hammer-blow is required, move the drift round the hole between blows so as not to concentrate the force on one spot and, possibly, distort the cover. Always inspect the springs when you are overhauling an H.M.V. motor; they are almost without exception struggling to overcome the resistance of solidified graphite-grease, and if left in this state will break sooner or later.

The VOYAGEUR RIFANCO-PHONE No. 100

PRICE £2 · 2 · 0

Exclusive Design. Our Own Make. The best of all. The latest improved and most compact portable Gramophone. Maximum advantages—Minimum space.

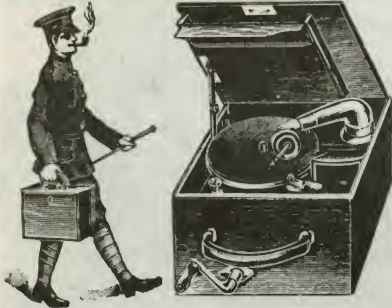

Size: 8in. high, 14in. long, 12in. wide. Weight 14lbs. Contains strong Motor, 10in. Table, Regulator, Brake, Winding Handle, Escutcheon, Nickelplated Tonearm, fine Soundbox, Lock and Key, Leather Carrying Handle, and Record Case to hold 12 to 18 10 in. discs, and a few 1,000 needles. This Rifanco-Phone produces as clear a sound as the largest and best Gramophone, as 65 per cent. of the interior cubic space is reserved for developing sound. The upper half of the Cabinet is hollow and directly connected with the little wooden Horn, which also acts as a rest for the Tonearm. There is also a Sound Reflector under the lid. This is the proper machine for open air use in the Garden, on Boats, Ships, in the Trenches.

1000 machines always in stock, 20 standard models from 196 each. Horn and Hornless Machines, Table Grams, Pedestals, Portables and various other types. Machines made to order. Millions of Rifanco-Elephant Needles. 12 types of Motors. Tonearms, Sound Boxes, All Accessories. 100,000 Besttone Records in stock. 80 pages of Illustrated Lists Free.

See RIFANCO-PHONE Transfer on Machines. Refuse substitutes.
THE REGENT WAVE CO.
(Manufacturers and Exporters), Telephone: 3203 London Wall.
Estab. 1903. 120, OLD STREET, LONDON, E.C.



NO. 85 RIFANCO-PHONE

Complete Horn Machine

£1 5s.

subject to discount for dealers.

Specification:
Cabinet piano-finished. Walnut, light or dark Oak, size about 12 1/2 x 12 1/2 x 6. Swiss Motor, 10in. Turntable, Top regulator and Brake, nickel-plated Arm, "Playwell" Sound Box.

From "Sound Wave", September 1915

Letter to the Editor

To the Editor:—Sir,

It is with great interest and much enjoyment that I have just read in the current issue of Hillandale News, the notes of Prof. Alan Debus, entitled "Victoria's World", which originally accompanied the taped programme he presented at the University of Chicago in 1970. How I would like to have been present!

The real reason for writing, however, is to comment on some of the disc details as given, which were the records played by Prof. Debus eight years ago.

Record No.1, Billy Williams (Phoenix 042). The stamper was marked X64, but the Columbia master number was 27409, not to be seen on the Phoenix, and was issued in March 1911 on Columbia-Rena 1566.

Record No.7, May Moore Duprez. The master 28388 was originally used to press Columbia-Rena Record 2109, first issued in April 1913, the Regal G6371 being its replacement 10 months later.

Record No.8, Johnny Wakefield. According to Ernie Bayly's list of Zonophone Records' pseudonyms, Mr. Wakefield was, in fact, Arthur Gilbert (also known as Arthur Osmond), a Music Hall performer who became exceedingly proficient as a recording expert (engineer) with British Edison, Beka Records and the Sound Recording Company. Billy Williams had been singing the "Taxi-Meter Car" song in 1907, and had recorded it for Edison 2 minute wax cylinders in the summer of that year. Whether Johnny Wakefield (Arthur Gilbert) was at the Edison studios when Williams recorded the song at the time, I cannot say; Williams was not yet recording for G. & T., who therefore used other artists to record Billy Williams' successes. That is why Arthur Gilbert, as Johnny Wakefield, came to record the title for G. & T.'s Zonophone label about six months after Williams' record had appeared on the market. (It was issued in February 1908). I do not know whether Arthur Gilbert appeared on stage as Johnny Wakefield or whether it was a name used for him, or by him, only when fulfilling the role of recording artist.

Record No.10, Wilkie Bard. The catalogue number of A23151, which was the record or face number, was A.203, a number which shows that there was an earlier Jumbo Record numbered 203, two items by Will Terry (another pseudonym, this time for Alf Gordon). Wilkie Bard's matrix number begins Lxo11, with two more digits to follow, the reverse having Lxo1149. Issued April 1911.

Record 11. Here is the chance to check Arthur Gilbert's voice on H.M.V. C490 with the Johnny Wakefield, record No.8. on Zonophone.

Record 12. Whit Cunliffe. The master 9827 is a Beka Grand Record master, which number also served as the catalogue number for single and double sided Beka Grand Records in October 1906. The Albion Record is a pressing from at least six years later.

Record 13. Wilkie Bard again. A23272 is not the master number, it is the record or face number. The master number is in doubt, but I have it as Lxo472. Confirmation, and the reverse matrix of Jumbo 295 is wanted by me. Issued in March 1909.

Record 14. In my attempt at completing a listing of Gramnavox Records I have a number of "Blank Entries", and, in the "E" prefixed series, Prof. Debus's E.114 is one of them! In fact I have an unknown block comprising E102 to E118, so if Prof. Debus would kindly send me full details of E.114 I would be most grateful. The disc was issued at some time between June 1913 and June 1914 inclusive. The only other "blanks" in this "E" series are:— E68, E73, E74, E75, E86 and any beyond E121.

Record 16. Geo. Grossmith, Jnr. A20861 is not the master number, it is the record or face number. The master number, commencing Lxo, is unknown, as is that on the reverse of Jumbo Record 415. Issued in December 1909.

Record 20. Vesta Tilley. A25113 is the record or face number, again the master number beginning Lxo, is not known nor that of its reverse. Jumbo Record 561 was issued December 1910.

Record 23. As Prince's Orchestra: U.S.A. Columbia disc master 3643 was issued in Britain on Columbia Double Face Record D119 in January 1908, the arrangement of Vesta Victoria's songs having been undertaken by Charles Prince himself.

Finally Record 26. Mark Sheridan. The Scala Record 414 was a late pressing from Sheridan's first Jumbo Record. No.416 issued in December 1909, with master number Lxo793 and record or face number A28056. The Scala Record should show the Fonotipia "Recognition Line" in the playing area, also the Lxo numbers under the label or near its edge.

The foregoing information is in no way meant to be a criticism of Prof. Debus's notes, and as an erst-while correspondent of his, I am sure he will approve any information which clarifies information already published or augments the same with fresh data.

Frank Andrews

Yes, I Remember It Well!

MY LIFE WITH THE PHONOGRAPH – by SYDNEY H. CARTER

1. SMALL BEGINNINGS

It all began very many years ago when out of my Birthday money I “fell” for an Edison Bell Puck Phonograph for five shillings and included with it, an Indestructible Cylinder entitled Valse Santiago. I wish I had it now!

This little machine (see illustration on page 36 of Mr. V.K. Chew’s book ‘Talking Machines’) has no lead screw, so it has to be played on a level table – or the reproducer, with the horn attached, will run rapidly across the record and fall off, probably damaging the reproducer.

Later models had a wire frame to catch the horn and reproducer.

2. THE GIFT

A year or two after this, I was invited by my sister Nellie and her husband Bert to spend part of my summer holiday with them at Tonbridge in Kent, where Bert was the Manager of a large Provision Store. After a few days with little to do, Bert asked me if I would like to earn some pocket money and give a hand at the Store, which I much enjoyed.



Sidney and Nellie Carter and their Humber Super Snipe, 1950 (Sorry there’s no gramophone in the picture – but I like old cars, too! – Ed.)

Some time before a food manufacturer had organised a competition with a large Flower Horn Gramophone and six records as the prize. No one had won it, and as the machine was getting in the way, Bert offered it to me if I could get it home on my bicycle.

I shall NEVER know how I managed that 36 mile journey from Tonbridge to Brighton with my small suitcase AND the Gramophone all strapped on the cycle – but I certainly did, and it was installed with the Puck Phonograph in my bedroom.

Those six disc records, plus 'Valse Santiago' became *very* well known all over the house. Pity I cannot remember the titles!

3. REAL ENTERTAINMENT AT LAST

A couple of years later, I had left School and was in business, earning £1 a week in my Father's and Uncle's firm in Brighton.

Walking down Queen's Road one day, I saw in Nelson's a lovely Edison Phonograph – price four guineas. I went in, listened to one record and it just HAD to be mine. So bang went some more of my Birthday savings, and once again I made my way home with a Talking Machine strapped on my bicycle, complete with a Morning Glory horn.

You will now probably guess that this was a Model A Edison FIRESIDE with a Model K two and four minute Reproducer.

I bought one record only – 'The Trio from Faust' Blue Amberol 1502 – and what will surprise all of you, I STILL have the FIRESIDE and that fine record. If you are this way at any time, come and hear it!!

The outfit included a black Morning Glory horn, but later I bought a 42 inch polished brass horn on a tripod stand, which provided greatly improved reproduction of Band music etc.

4. THE NEXT STAGE

My wife Nellie and I were married in June 1920 and I soon realised that besides a nice Piano, we must have an attractive Gramophone in our Living Room.

A dealer in Brighton offered to make one up for me, with a hand-made mahogany cabinet, gilt tone-arm and a big polished brass petalled horn – all for four guineas!

It looked wonderful, and gave lots of volume and pleasure – as long as you did not listen to the rather annoying surface scratch from those early acoustic 78's.

5. THE BROADCASTING ERA

A few more years have quickly passed, and we are now in 1923.

The first B.B.C. Station 2LO had commenced regular broadcast programmes in November 1922, and as I had been doing quite a lot of experimental work I designed and assembled my first four valve Receiver, obtaining the bright-emitter ORA Valves direct from the Mullard Radio Valve Company at Hammersmith.

It soon became apparent that there would be a huge demand for component parts for the home construction radio receivers, so in January 1924 I opened the basement of our Western Road premises as a new Radio Department.

The Brighton Radio Stores was an immediate success, and we quickly felt the need to demonstrate various model loudspeakers by comparison, when NO music was being broadcast from 2LO.

Once again, my Edison Fireside Phonograph came to the fore, and I constructed a Phone Pick-up from an S.G. Brown earphone, coupled to a two-stage Amplifier.



View of Carter's Stores, Brighton, in 1927. Notice the shop next door, as well: Murdoch, Murdoch & Co., a retail outlet of the factors the Murdoch Trading Co., and one of the biggest gramophone shops in the south, to judge from the number of machines that turn up with their name inside. What a shame they put their blinds down when the photograph was taken!

This was installed in a small cabin under the stairs, with a line running to a series of plugs on the loudspeaker display shelves. When a customer wished to select a loudspeaker, one of the junior assistants went into the cabin, put on a four minute Amberol record and turned up the amplifier.

These comparative demonstrations were remarkably successful, and dozens of Celestion, Amplion, Blue-Spot and other popular makes of loudspeaker were sold as a result.

I can hardly believe that all this happened well over 50 years ago!

6. TIME MARCHES ON

We spent much of the time between 1948 and 1956 in Australia, Tasmania and New Zealand, where I once had the offer of a Model B, G E M Phonograph for only £5. (Australian).

In 1960 Nellie and I moved from London to our present home in Worthing, and here I found many opportunities to buy good Phonographs and Gramophones at very reasonable prices.

I built up a large collection of different models, and with the help of friends, displayed them at the first Phonograph and Gramophone Exhibition at the Museum and Art Gallery at Worthing, in July 1962.

The Exhibition went over well and demonstrations of different models were given every afternoon.

7. SPARE PARTS

From 1960 onwards, I also undertook the manufacture and supply of various spare parts — Winding Handles, Diaphragms, Leather Belting, Stylus etc. etc., and this grew and grew taking up much time, so in 1970 I decided to pass the work over completely to the City of London Phono Society, where as we all know, it has become an important part of its activities, and a wonderful help to members.

8. THE EDISON RECORD CATALOGUES

The constant demand for spares also brought requests for record catalogues, so Nellie and I set to work and finally produced a complete listing of the Edison Blue Amberol records in numerical order. The set of three volumes, including all the United States, British and ALL the Foreign issues have sold freely, and quickly became out of print.

A new and fully revised Edition in one volume has just been published and is available, by return, from the Talking Machine Review of Bournemouth, price £4.40 — post free. Complete listings (in seven volumes) of the Edison two-minute Gold-Moulded cylinder records, 1902 to 1912, the Edison four minute Wax Amberol records 1908—1912 (in three volumes) and the British Edison Bell two and four minute cylinders (in two volumes) have also been prepared. I sincerely hope that it will be possible to produce new revised editions of these, later on.

9. THE SECOND PHONOGRAPH AND GRAMOPHONE EXHIBITION IN WORTHING 1965

The great interest aroused by the 1962 Phonograph Exhibition prompted the Curator and Museum Committee to invite me to stage a further and more extensive Exhibition in 1965, and in this the Society fully co-operated.

My special thanks go to my dear friend George Frow for bringing down and displaying a number of scarce and very fine exhibits, including a valuable Edison Bijou 'Penny-in-the-Slot' Phonograph.

The Museum Committee provided 200 catalogues of the display all of which sold quickly and by Wednesday it was necessary to print a whole second edition.

10. BROADCAST PROGRAMMES

Soon after the Phonograph Exhibition, the B.B.C. kindly invited me to prepare some fifteen minute Feature Programmes with Phonograph recordings for the Home Service 'HOME THIS AFTERNOON' programme.

The first of these was broadcast on Boxing Day 1965, and was entitled 'A NIGHT AT THE MUSIC HALL'.

Three other fifteen minute features were prepared and broadcast, their titles being:—

'POOR OLD DAD'

'THEY CALLED IT RAGTIME'

and 'DEM OLE PLANTATION SONGS'

They all went over well, and I had many pleasant letters from listeners.

11. ELECTRICAL REPRODUCTION

From 1924 onwards — when I prepared the first pick-up for demonstrating loud-speakers, using the magnet assembly from an S.G. Brown's earphone — I was impressed with the quality of reproduction obtainable from the Wax and Blue Amberol cylinders by this means.

In preparing for the 1962 Phonograph and Gramophone Exhibition in Worthing, I decided that it would be a good idea to have a means of amplifying the records, so that they would be clearly heard in a large hall.

The original pick-up had certain faults, so I turned to the use of a modern ACOS turn-over Stereo Cartridge with the connections re-arranged to give maximum vertical response. Using the '78' unit with .0025 sapphire stylus mounted on a light cantilever, the system worked quite well on two and four minute wax cylinders. For Blue Amberols however, a problem arose, for with them many of these had become very slightly mis-shapen and produced an annoying 160 r.p.m. 'thump' — which we could reduce but not eliminate.

So in collaboration with my friend Fred Arkell, a retired B.T.H. Co. precision engineer, we developed a new electro-magnetic (balanced armature) unit for the 1965 Exhibition.

This proved very satisfactory and was used for all the cylinder record Broadcast 'HOME THIS AFTERNOON' programmes in 1965 and 1966.

Many tape recordings of scarce records were prepared with this equipment.

I am now experimenting with a new and more complex Regenerative System, but further details of this later on.

So my quest for even finer and more natural reproduction goes on, and I STILL marvel at the high quality and silent background achieved by the Edison Company from 1902 onwards by the hill-and-dale system, with a clarity frequently superior to the laterally recorded L.P. disc records of today.

A Controversy over Amberols



In 1910, following the introduction of the wax Amberol four-minute records by Edison, a fierce controversy was carried on in the correspondence columns of the *Talking Machine News* and *Journal of Amusements*.

The protagonists were Adrian Sykes and Henry Seymour. Both were Edison enthusiasts, both inventors in their own right, both involved at one time or another in the English talking machine industry and both had interests in disc machines in later years.

Both were also 'Society' men. Adrian Sykes, indeed, was the founder of the movement which began to flourish around 1911 and has continued to this day. Both he and Seymour were officers in the North London Phonograph and Gramophone Society before the Great War, and Sykes was the first President of the City of London Phonograph Society (formed in 1919 as the London Edison Society, changing its name at Edison's request and known today as the City of London Phonograph and Gramophone Society). The North London Society was formed in 1911.

The controversy opened in the January issue of the *Talking Machine News*, and was brought to an end by the Editor in September. We are reproducing herewith (and in subsequent issues) a selection of the correspondence.

Frank Andrews

FEB 1910

A. F. Sykes (*New Barnet*) writes:—With reference to Mr. Henry Seymour's article last month, may I be permitted to offer a few words of criticism. He says that he is perfectly convinced that no wax-like substance can succeed as a record material for a track so fine as 200 threads per inch. As an enthusiast for Edison Amberol records I can say that if used on an Edison phonograph these records are as durable, if not more so than the present standard record. The material seems to be of a much tougher nature and not inclined to chip. On the other hand it is true that the walls of the track are weak, and this necessitates swivelling arrangements, therefore records should not be used on phonographs with floating reproducers. Mr. Seymour favours the floating reproducer, and it is no wonder that he does not think much of the 200 thread record, since such a reproducer rapidly cuts them up.

While agreeing with Mr. Seymour that there is more in the Amberol record than is evident from the average reproduction, I disagree entirely with his views on the reproducer question. It is well known that Edison phonographs are now fitted with corrugated copper diaphragms. These latter have made an extraordinary difference to the reproduction. On examining an Edison reproducer,

it will be observed that the surface of the diaphragm moves as a whole in a remarkably flat manner. Now, in my opinion, the quality and fullness of the reproduction depend upon the manner in which the surface of the diaphragm moves as a whole, the ideal being attained when the surface remains flat as it moves. The new copper diaphragms exhibit this quality in a remarkable degree, and thus the reproduction is characterised by a richness and fullness that was absent before. I ought, however, to qualify this statement for it seems next to impossible to ensure uniform results. Anyone who has to do with talking machines knows that sound-boxes vary immensely in quality, and I am inclined to think this is largely responsible for the extreme difference of opinion as to the merits of various machines. However, by obtaining several diaphragms, and using the utmost care in the mounting so as to ensure that the diaphragm is free from initial strain, excellent results can be obtained. It will be gathered from the foregoing remarks that I think Edison methods are the best to reproduce Amberol records. As far as volume is concerned, I consider that with a large flower horn we have quite enough for ordinary purposes. I say large horn, because such a horn gives a much more real reproduction. Personally I prefer quality of reproduction to volume.

I should like to say just a word or two regarding indestructible records. Since the National Phonograph Co. have shown that it is possible to produce 200 thread records in wax composition, may it not be possible to produce 400 thread records in indestructible composition? This idea carried into effect on a 4¼ in. cylinder would produce a ten minute record. I do not see why we should be limited to the present length of cylinders; a 400 thread indestructible cylinder 14 in. in length would play for 30 minutes, and render long symphonies possible. In conclusion, let me remark that although I disagree with some of Mr. Seymour's opinions, I always look forward to his interesting articles.



MARCH 1910 A CRITICISM CRITICISED by Henry Seymour

Apropos of my recent contribution on the 'Talking Machine Outlook', Mr. A.F. Sykes writes in the last issue an important letter in criticism thereof, which, however, may claim to be much more interesting than convincing. On some points, it seems, we are in common agreement, but on others we are diametrically opposed. With my statement that wax-like substances are unfitted for record material bearing so fine a track as 200 threads to the inch Mr. Sykes joins issue entirely, and he declares that the Amberol material is virtually proof against wear if played on an Edison phonograph, leading to the inference that it is very easily destroyed if played on any competitive machine. What I ask Mr. Sykes very plainly is this: In what way does a machine *per se* operate either to preserve or injure a record played upon it? Will he be good enough to point out the particular way in which any other phonograph than Edison's causes the Amberol record to be destroyed more easily?

I daresay Mr. Sykes will explain that he did not mean the machine (although he said so), but the reproducer was what he had in his mind. Very well; we will not quibble. But what I want Mr. Sykes to explain is, what there is in one form of reproducer and not in another that favours the destructive process? He has already said that "the walls of the track are weak, and this necessitates swivelling arrangements, therefore records should not be used on phonographs with floating reproducers." Here

we have it. The cause of the trouble in Mr. Sykes' mind is obviously the floating reproducer. A very pious opinion!

I ask two more questions: If the Edison reproducer is not, in all essential particulars, a floating reproducer, what is? Has Mr. Sykes ever seen a floating reproducer of any other type without being furnished with a swivelling arrangement to facilitate tracking? Obviously, then, it is neither the machine nor the reproducer which have anything to do with it. I will go further and say without fear of confutation by anyone who understands what he is talking about, that the mere difference in type of construction (such as is apparent in the Edison models and, say, the old Columbia models) of reproducer has no effect whatever upon the wear of any record. But a difference in weight upon the record surface will, a difference in the size, shape and polish of the reproducing stylus will, the angle at which the stylus is set in relation to the record surface will, and there we exhaust the possible causes of the trouble complained of, and complained of, not alone by me, but by large numbers of people who are Amberol enthusiasts and who rigidly stick to the Edison reproducer into the bargain.

On the question of superiority of tone in the Amberol record about which Mr. Sykes and I are much in agreement, I am bound to point out that Mr. Sykes appears to be very uncertain, while presuming to know for certain, about the causes which contribute to this improvement. First, it is the comparative elimination of the resistance by the blank in the recording—and here Mr. Sykes has the temerity to indulge in the humorous suggestion that the blank should be abolished altogether while preserving the record! But even in vibratory physics you can't have your cake and eat it, too. Next it is the copper diaphragm of the Model H reproducer that has wrought this miraculous achievement.

Now, which is it? The reduction of blank resistance in the recording, or the copper diaphragm in the reproducing? Is it either? I say, No, most emphatically.

It will, of course, be obvious to the merest novice that a recording stylus measuring less than half in its cutting surface of that of the standard stylus will present theoretical advantages in the recording of delicate vibrations on soap blanks of equal density which will be entirely absent in the larger stylus. We obtain not only a smaller resistance, but a greater increment of depth in the cut. So far, so good. But these advantages resolve themselves practically into one, viz., the greater facility to record sounds of the minor order, the

relatively deeper cut of the more robust tones being entirely negated by the restricted width of the track, as can be easily proved by recording on a 100-thread feed pitch with a 200-thread stylus. By the latter process, we secure adequate clearance, which provides a still more perfect reproduction than any Amberol I have heard. The wear is considerably less because the upper edges of the track are not like razor edges and therefore unable to withstand the least friction. This difficulty, at any rate, may be overcome by the use of celluloid or similar substance as the record material, as I have also proved by definite experiment.

Opinions count for very little in scientific research unless they conform to severe test by actual experiment conducted with the most careful discrimination. On the subject of the corrugated copper diaphragm, I may be pardoned for informing Mr. Sykes that it was in use in connection with Edison reproducers and Standard records long before the Model H was heard of. I am therefore unable to agree with Mr. Sykes that the copper diaphragm in the Model H, when used with Amberol records, is responsible for "a richness and fullness that was absent before." As to the supposed advantage of the diaphragm moving as a whole, instead of its movement being one of graduated distance between centre and periphery, I can assure Mr. Sykes that he is hopelessly wrong. I will add this proviso—unless the record itself has been made by means of a similarly constituted diaphragm. Even in this combination of circumstances, the theory conflicts with the practice, as I have also proved by definite experiment long ago. I found that too great a discrepancy occurred between the major and minor sounds, rendering the result far more 'mechanical' than if made and reproduced in the ordinary way. Building up a diaphragm, as is often done with certain advantages, would appear, superficially, to negative this contention, but such is not the case. The effect of building up and stiffening the central area of a diaphragm is the promotion of a more rapid recovery without impeding in any marked degree its capacity of amplitude. Even this process has its evils in preventing the reproduction of the very minor sounds of the record, and the real object of the corrugated diaphragm is to obtain the maximum amplitude, together with the maximum rapidity of recovery in a reproducer of limited powers. And in no sense does it move, as Mr. Sykes innocently supposes, by remaining flat as it moves.

In conclusion, I will venture an opinion, in contradistinction to that of Mr. Sykes, as to the actual cause of the tonal superiority of the Amberol over the Standard record. I know of no

method of experiment, except that of comparative analogy, capable of subjecting this opinion to the canons of scientific test. It is therefore based, as all hypotheses must be based, on the processes of logical analysis and deduction. The improved tone of the Amberol, then, is due to the relative extension of the sound waves in the track, and nothing else. My premises to justify this conclusion are based partly on observation with experience as a guide. And in this particular I call attention to the fact that the difference as to tone between the Amberol and the Standard records is just precisely the same difference which exists between the now effete Concert record and the Standard. As to volume, the difference is in the inverted order. If we microscopically examine the respective record tracks of the Concert and Amberol, we find they are identical in *form*, presenting only a very marked difference in *size*. The Amberol may therefore be properly regarded as a miniature Concert record. The wave-lengths of the Amberol are certainly not greater in length than those of the Standard record, but in being only half the width they are *relatively* twice as long. It is purely a question of relativity. Here then, is the obviously reasonable explanation of the Amberol tone. Now as to volume. The Amberol track being only half as wide as the Standard record track, the volume is correspondingly reduced by the corresponding absence of surface friction. This surface friction, it must be borne in mind, is the proximate source of all sound reproduced, and the idea of eliminating friction (which means wear) is a technical stupidity. A given weight in the reproducer is indispensable to give rise to this necessary friction, and if this condition is absent, the record will never be effectually reproduced. The material of the Amberol record is admittedly of greater density than that of the ordinary cylinder record, but it is not hard enough to maintain adequate friction while reducing wear to the practical minimum. The necessity to employ a contractile material for use in a cylindrical mould on the surface of whose interior are thousands of minute projections corresponding, obversely, with the sound waves depressed into the original blank, makes it extremely difficult to employ a wax-like material of sufficient density to answer the purpose successfully. I have found, as I have before said, that celluloid is an ideal substance to effect the object in view, without the least loss in any other particular. And with such a substance the problem of the reproducer vanishes entirely. The maximum weight necessary may be used without the least injury to the record, and both volume and quality are increased enormously.



APRIL 1910

THE AMBEROL CONTROVERSY

J.H. (Regent's Park) writes:—Dear Sir,—I have read with great interest the letters of Mr. Seymour and Mr. Sykes, and I must say, as a practical user, that I quite agree with the former. I was very sorry, from a user's point of view, when the Edison record was reduced in price; there are none now that will stand the wear and tear like some I have. Look, for instance, what fine wearing records the first Gold Moulded cylinders were. I have some now, with the wadding still round them, as good now as when I bought them in 1905, and they are used in the summer as well as in the winter. As regards reproducers, I have been user (not dealer) for 14 years, and have had all kinds of machines in that time, from the Model Gem up to the Triumph. The Edison Co. some years ago brought out a machine fitted with a copper diaphragm, then I bought a new Standard fitted with mica; now the Edison Co. are sending some of their machines out again with copper diaphragms. Which is better—copper or mica? In my opinion neither are much good. I have tested all kinds of diaphragms—sheepskin, carbon, sandpaper, and I never found anything yet that would beat the article that the makers use for recording purposes, namely, glass;—but it must be of the right thickness. Now, if readers want to improve their Model C's or Lyrics, do as I do with mine: Go to the dealer and get a few Edison pattern glasses, measuring exactly 7.40mm in thickness. It is of the utmost importance that the correct size is procured, because if the glass is too thick the sound will be tubby, and if too thin the sound will be sharp and will blast, but if the glass is the right thickness and is adjusted correctly it will give a tone that for fullness and richness cannot be obtained from copper or mica. I might say, in sticking the cross-head to the diaphragm, use Mendine, and see that the link is not too thick. I find also by bending the link to the shape of the letter S one gets a purer sound—this wrinkle I learnt from the "T.M.N." a few years ago.



A DEFENCE

Dear Sir,—Mr. Henry Seymour has criticised my letter at some length and I will do my best to reply to his objections. First, let us reconsider the question of wear of the Amberol records. We have the assurance of the National Phonograph Co. that their long records are as durable, if not more so, than the present Standard record, and I would bring it to Mr. Seymour's notice that they are issuing records of the greatest singers, and at 4s. too, a fact which shows that they have faith in the material of their records. Furthermore, as a user of Amberol records I state that I have not experienced the wear that Mr. Seymour complains of. I am asked very plainly to explain why the Amberols must be played on an Edison phonograph; and I will give a plain answer. The Edison, Model H, is fitted with a stylus-bar that is freely swivelled. This allows the track to be slightly out of truth, a not uncommon occurrence, and yet no harm results to the record when played. Again, unless the sapphire is set with extreme care with the floating reproducer it cannot reach the bottom of the track without breaking down the walls. Mr. Seymour says the floating reproducer is swivelled; quite so, but in the wrong place. Given perfect conditions, no doubt the wearing effects would be identical, but in practice the ideal conditions are unattainable. My advice to those thinking of taking up the Amberol record is scrap your machine with floating reproducer and go in for a genuine Edison, which will spell satisfaction instead of disappointment. I have good reason to appreciate the value of the swivelling device, since after experimenting with my Model H, I accidentally got the swivel pin too tight a fit. The result was the spoiling of the commencement of some half-dozen Amberols. On grinding in the pin afresh the trouble disappeared. Again, the small sapphires are easily chipped and should be treated with care. Let me here remark that the Edison reproducer cannot be called a floating reproducer because (1) the diaphragm does not float; (2) the thrust from the record is not direct. Mr. Seymour knows very well what is meant by a floating reproducer, and I consider his remarks a mere quibble.

As Mr. Seymour is well aware, speech possesses comparatively little energy, and to obtain theoretically perfect results all frictional resistance must be abolished. The record acts as a damping resistance, and Mr. Seymour admits that the stylus is able to penetrate the blank more easily with the 200-thread systems. It will be obvious that the stylus will find less difficulty in leaving the blank than entering it. Thus serious distortion is introduced, and it is indeed remarkable that the results

obtained should be of such excellence considering the errors introduced. As to Mr. Henry Seymour's rather quaint little joke at my expense regarding abolition of blank, perhaps I should have said recording blank, surely Mr. Seymour can imagine a system in which no mechanical indentation is necessary to secure an initial record. Let me draw his attention to the system of recording by means of the 'local magnetisation of iron wire'. I do not suppose Mr. Seymour will claim that existing methods of reproduction are perfect. Mr. Seymour says, "Now, which is it, the reduction of blank resistance or the copper diaphragm that has wrought this miraculous achievement?" He says neither. I say both, and there was really no cause for a misunderstanding. My remarks in connection with the copper diaphragm were intended to include Standard as well as Amberol records. As I have experimented with no less than twelve Edison coppers I feel justified in claiming some knowledge of their properties. Let Mr. Seymour play Amberols with glass, mica, ivory, or any of the patent diaphragms on the market, all fitted to a Model H. He will then realise how vastly superior the corrugated diaphragm is, richer, fuller, clearer, more brilliant. This is quite apart from the theoretical explanation, another point about which we differ. I wish it to be understood that I mean that Standard records are reproduced vastly better also with the copper diaphragm; in fact, I have no intention myself of giving up the Standard record, especially having regard to the excellence that is now being obtained in their recording. Mr. Seymour scoffs at my explanation that the surface tends to move in a flatter manner. This will depend upon whether the corrugations tend to stiffen the centre or not. My point is that they do, and this without appreciably increasing the weight. They would doubtless also have other properties, but why give the diaphragm a more rapid recovery? The idea that if the reproducing diaphragm does not move in the same manner as the recording diaphragm (I am here thinking of the relative motion of the various parts) then it cannot reproduce the original sound is in my opinion fallacious. Mr. Seymour's ideas on this subject are rather inconsistent. Elsewhere he has published the statement that a record can be successfully reproduced by compressed air. This would seem to imply that if we set up waves in the air which are copies of those on the record, the original would be reproduced. Now will he explain to me why a diaphragm acting like a piston cannot effect this or why the compressed air system sets up waves that are different from those on the record? In Mr. Seymour's criticism I notice he makes the

astonishing statement that the Amberol track being less than half the width of the Standard track, therefore the volume of sound is correspondingly reduced. Really, this quite takes one's breath away. As a start, I totally disagree that the Amberol records have appreciably less volume than the Standard. I advise him to try "Rocked in the Cradle of the Deep," Amberol 35. There is a certain reason, it is true, why the long records should reproduce with slightly less volume than the Standard, and that is they are played with what is really a small ball sapphire, while the Standards are or should be played with the regulation button. Volume or intensity mean amplitude of resulting sound waves and depend upon the maximum velocity at which the diaphragm is called upon to move, also upon the amount of surface moving. The inference is that I regard the friction hypothesis with dissatisfaction. Also I would point out to Mr. Seymour that the force of friction depends purely upon the normal reaction between the surfaces, and is independent of the area of contact. Again, it acts at right angles to the motion of the stylus, and thus cannot influence that motion. I put it to Mr. Seymour that if friction is the cause of sound, would not the beautiful hard, polished surface of Edison cylinders mean that inferior cylinders with a gritty surface would be much louder? Everyone knows this is not the case. As Mr. Seymour remarks, a given weight or pressure is necessary to reproduce a record adequately, but we differ radically on the explanation. He says to produce sufficient friction, while I contend to produce sufficient initial strain and stress in the diaphragm. So many points have been raised that it is next to impossible to treat them adequately within the limits of a letter. If he will agree to restrict the discussion to the more important points, I shall be pleased to consider them more in detail. I will end with the remark that in my opinion Mr. Seymour's explanation of the difference in tonal quality between Amberol and Standard more fully merits the epithet "More interesting than convincing."

Adrian F. Sykes



ANOTHER CONTROVERSIALIST

Dear Sir,—As it is some time since I have had the pleasure of contributing to the "T.M.N.", I feel I must say a word or two in reference to the letters by Mr. Henry Seymour and Mr. Sykes. I was certainly amused at the latter gentleman's idea that a Seymour reproducer was not swivelled. As Mr. Seymour is aware, I am a great admirer of his floating reproducer, especially when used with a cork diaphragm, and all my friends who use the Edison repros. most emphatically give the palm to the floating arrangement as compared with the fixed cell. I do not, of course, mean that a floating repro. with, say, a 2 in. diaphragm, would be any better than a fixed cell repro. with the same size of diaphragm, because I have never either seen or heard the latter, if one exists, but I entirely agree with Mr. Seymour that the large diaphragm gives infinitely better results than the Edison size. Mr. Sykes is, I think, somewhat prejudiced in favour of Edison's arrangement of the small diaphragm, and yet, as I pointed out recently in a contemporary, the new Amberol machine of Edison's has a much larger diaphragm than the old type—I believe either 1¾ in. or 2 in.

I confess I do not see why the Model H needs such a lot of lateral movement on a 200 thread

track, for it has the motion from the fan tail hinge, and also an extra swivel on the stylus-bar hinge. It seems to me that this dual arrangement is necessary in the Model C for a 100 thread track. I notice that Mr. Seymour advocates the cutting of the 100 thread or Standard records with a 200 thread sapphire, so that the walls would be much thicker. This I myself suggested about a year ago, not for the reasons given by Mr. Seymour, which I did not know (viz. that the track was practically the same as the obsolete concert records), but that if all cylinders had the narrow track (whether 2½ or 5 minutes) *the same reproducer and sapphire could be used.* I do not quite follow Mr. Seymour on p.145 of March issue when he says, "The wave-lengths of the Amberol are certainly not greater in length than those of the Standard record, but in being only half the width they are relatively twice as long." What I want to know is relatively to what? If the Concert record were made at a speed of 100 r.p.m. with a 200 thread cut instead of 100, would the tone be much superior with the former than the latter? Must a 200 thread record of necessity be better in tone than that of a 100 thread?

Yours, etc., Linzey A. Willcox, Newcastle-on-Tyne



Postcard from Wales, 1907. Translation of the songsheet: National Airs which have been arranged by the young nightingale of Glanrhosydd. (Kindly lent by Sidney Carter)



**STANDARD
COLUMBIA PORTABLE.
Five Styles.**

- No. 112a. . . . Standard Black Grained Leather Cloth.
- No. 112a. . . . Blue Crocodile Leather Cloth.
- No. 112a. . . . Brown Crocodile Leather Cloth.
- No. 112a. . . . Red Crocodile Leather Cloth.
- No. 111aN. . . . Brown Cowhide (Nickel-Plated Fittings).
- No. 111aGP. . . . Brown Cowhide (Gold-Plated Fittings).

Each carries Eight 10-in. Records.

An Amazing Standard in Tone and Value.
CABINET—Shaped like an Attache Case, with handle, and two locks. Constructed in selected hardwood, covered as noted above. Length 16½-ins., width 11½-ins., height 6½-ins. Spring-cover Needle Cup. Nickel-plated carrier in lid for Eight 10-in. Records. Specially powerful British-made Single-Spring Motor, to play 10-in. and 12-in. Records. 10-in. Turntable, Velvet covered, nickel-plated flange. Finned winding crank falls into cabinet. New type Columbia "Plano-reflex" Tone-Arm, improved "goose-neck" pattern, connected with scientific tone conduit and amplifier. New Columbia "No. 9" Sound-Box.

For Prices see Outside Page.



- No. 2a **HORN MODEL.**
 Oak Cabinet. Size 16 x 16 x 8½-ins. high. Extra powerful British Single-Spring Motor. 11-in. Turntable. Black enamelled metal Horn, with gold lines. New Columbia "Plano-reflex" Tone-Arm. Fitted with new "No. 9" Sound-Box.

For Price see Outside Page.

1929 Viva-tonal Columbia w

A NEW GRAMOPHONE a new thrill! The introduction of the 1929 Viva-tonal Columbia constitutes another important gramophone advance. New principles of sound amplification are employed, these new principles being summarised in the term "Plano-reflex." . . . Simply explained, these principles are those upon which by the use of reflecting surfaces a beam of light can be conveyed or transmitted, and in its course duly enlarged, without distortion. Substitute a wave of sound for a beam of light and the new method of "Plano-reflex" reproduction is made clear. The diagrams demonstrate this straight-line

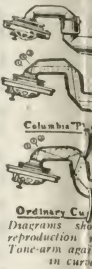

PRICES.

1929 COLUMBIA MODELS

(Not for Irish Free State).

No. 2a	Horn Model	£	s. d.
No. 117a	Oak, Small Table Grand	6	10 0
No. 118a	Mahogany, Small Table Grand	7	10 0
No. 119a	Oak, Standard Table Grand	8	10 0
No. 120a	Mahogany, Standard Table Grand	9	10 0
No. 123a	Oak, New Boudoir Cabinet	11	10 0
No. 124a	Mahogany, New Boudoir Cabinet	12	15 0
No. 125a	Oak, Cabinet	14	10 0
No. 126a	Mahogany, Cabinet	15	15 0
No. 131a	Mahogany, Cabinet	50	guineas
No. 132a	Oak, New Cabinet	18	18 0
No. 133a	Mahogany, New Cabinet	21	10 0
No. 134a	Mahogany, New Cabinet	30	0 0
No. 153a	Oak, Console	14	10 0
No. 154a	Mahogany, Console	15	15 0
No. 155a	Oak, Console	25	0 0
No. 156a	Mahogany, Console	27	10 0

1929 PORTABLE MODELS

No. 109a	Portable "Junior"	3	10 0
No. 111aN	Leather Portable (Nickel Fittings)	7	10 0
No. 111aGP	Leather Portable (Gold-Plated Fittings)	9	9 0
No. 112a	Standard Columbia Portable	4	15 0
No. 112a	Crocodile Cloth Portable	5	10 0
No. 113a	Crocodile Cloth Portable Viva-tonal Model	10	10 0

Canvas Cover for Portable Models Nos. 111a and 112a. 10 6

COLUMBIA NEEDLES.

SUPERBE (Loud Tone)	200	1,000
BRILLIANT (Medium)	9d.	3 9
IDEAL (Soft Tone)	9d.	3 9
DE LUXE (Tested)	1/-	5/-
SPEAR-POINT (Two-Tone)	1/-	5/-
FIBRE NEEDLES	4/-	—
New "DURAGOLD" (Semi-Permanent) Needles (Playing ten records)	100,	1/-
Columbia FIBRE NEEDLE CUTTER.	Price,	4/-

Columbia RECORD-CLEANING PAD .. 1/-

With "Plano-reflex" Principles.



amplification as against distorting cross-reflections in previous tone-arms. . . . The "Plano-reflex" principles are employed in the tone-arms of all new models, together with a new and more sensitive sound-box, while in larger models (Cabinets Nos. 131a, 132a, 133a, 134a, and Consoles Nos. 155a and 156a) the amplifying chamber is also constructed on "Plano-reflex" principles. . . . The result in every case is an amazing improvement in tone, brilliance, sonority and volume, while the range of effectively equal response has been extended to a range of seven octaves. . . . Test and compare for yourself.

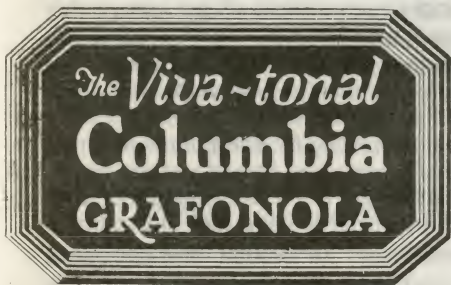

NEW 1929 MODELS
WITH
"PLANO-REFLEX"
PRINCIPLES



No. 109a. Black Grained Leather Cloth.

Carries Eight 10-in. Records.
The Biggest Portable Value known.

CABINET—Shaped like an Attache Case, with handle, and two locks. Constructed of selected timber, covered black Morocco-grain Leather Cloth. Length 15½ ins., width 11½ ins., height 8½ ins. Spring-cover Needle Cup. Carrier in lid for Eight 10-in. Records. Powerful British-made Single-Spring Motor, to play 10-in. and 12-in. Records. 10-in. Turntable, Velvet covered, nickel-plated Flange. Hinged winding crank folds into cabinet. New type Columbia "Plano-reflex" Tone-Arm, improved "goose neck" pattern, connected with scientific tone conduit and reflector. New Columbia "No. 9" Sound-Box.

For Price see Outside Page.



No. 113a. Blue Crocodile Leather Cloth.

Carries 10-in. and 12-in. Records in Lid.
The Most Phenomenal Tone of Any Portable.

CABINET—Shaped like an Attache Case, with handle, and two locks. Constructed in selected hardwood, covered Smoke Blue Leather Cloth. Length 17½ ins., width 11½ ins., height 8½ ins. Carrier in lid to hold 10-in. and 12-in. Records. Powerful British-made Double-Spring Motor. 10-in. Turntable, Velvet-covered. Hinged winding crank folds into cabinet. New Columbia Duplex-Curve Tone-Arm, with perfect sound conduit operating on sensitive balanced bearings. Specially designed Tone-Chamber, combining with metal side-wings and resonator lid, providing phenomenal Tone and Volume. All fittings brass-plated. New fixed Columbia Floating Sound-Box.

For Price see Outside Page.

Catching the Worm...

BY GEORGE FROW

being a brief look at early bird recordings, and some a little later

There are a number of bird-watchers around these days; they are to be encountered in the woods and fields even in the cold of winter with field-glasses and cameras, and the Royal Society for the Protection of Birds has never had such a following.

However as a family, we are not so inclined, and in fact eat quite a number of birds throughout the year, the largest one at Christmas. Probably the late Ludwig Koch did so as well, but he followed the birds with a recording machine and certainly made the earliest surviving record of a singing bird, a cylinder of an Indian shamah in 1889. Koch was in his younger days a Lieder singer and pupil of Jean de Reszke.

Later in the nineteen-thirties he made his bird recordings in Britain with 78 r.p.m. equipment until about 1950, and some of this apparatus is preserved in the Science Museum in London. Compared to the ease and portability of tape recording and recorders, 78 must have been appallingly frustrating and the equipment clumsy; those who used it knew no other, but recordings dating from this period generally show heavy surface noise, having been edited and re-recorded possibly several times. Some records of bird song obtained by Koch were published by J.F. & G. Witherby Ltd., the London booksellers, in 1930 (*Songs of Wild Birds*), and a further number a few years later (*More Songs of Wild Birds*). I know of Nos. 1 & 2 of the first, and 1 to 5 of the second, but have no knowledge of the full extent of the issue or whether booklets were published, but with Witherby's preoccupation with the outdoor world and Koch's explanatory policy, this is very likely.

Ludwig Koch was also associated with the recording side of *Hunting by Ear*, published in 1937 again by Witherby, for a guinea (£1.05p). Whereas this is not a bird record and one hears huntsmen, hounds and horn and ne'er a twitter from the hedgerows, it is a fine example of one of Koch's "Sound Books", originated by him in Germany with visual and auditory illustrations linked to the text. There are two 10-inch records in a box with a well-presented book, and it is an attractive item for the collector to look for.

In 1953-4 H.M.V. issued four 10-inch 78's (B 10473-6), which were afterwards made in 45 form, entitled *Songs of British Birds*. These were from B.B.C. sources and recorded by Koch originally; each record offered examples of different bird localities — Gardens and Parks, Birds of the Woodland, Fields and Hedgerows, Riverside and Marshland, and a booklet for two shillings (now 10p.) might be ordered through H.M.V.

A much earlier bird-man was Karl Reich of Bremen, who had several bird records in the British H.M.V. catalogue before 1914, and possibly more in the German. His earliest would seem to be the nightingale on single-sided 9439, which was later re-pressed on B 467, with a musical piece as backing. There was also a nightingale to sing on both sides of B 390 and a blackbird and thrush on B 392. The exact dates of issue of these records escape me at present, but 9439 was probably 1910; catalogues of this period are scarce, which is before the Society's 1911 and 1912 reprints.

The nightingale on B 390 was used at concerts in early presentations of the movement "Pines of the Janiculum" from Respighi's suite "The Pines of Rome" (1924), first performed in Rome in 1925, and by Toscanini at Carnegie Hall in 1926. Captive birds were used for such recordings by Reich.

He kept about 200 birds in the Bremen aviaries, and breeders used recordings of the Hartz Mountain Roller Canary as a model to their young singing birds; while the young was kept in the dark, the record was played to it time and time again. Another of Reich's tricks was more exacting and upsetting to family stability. As soon as the hen canary's eggs were hatched, the husband was replaced by a cock nightingale, who fathered the young and taught them to sing, and by dieting several such young birds they could be made to sing at different times of the year, thus having instant nightingale song available at any time. To what purpose, there is no indication.

Fred Gaisberg reported that Reich separated the canaries from all birds other than nightingales, and after several generations the canaries acquired full nightingale song, a less drastic way of achieving the object. A number of commercial records were made at Reich's aviaries, of canaries and woodland birds. Sometimes when recording, an orchestra was kept in attendance to accompany the birds, but this was not always successful as Gaisberg reports the musicians found it impossible to sit still and quiet for long enough while the birds were coaxed into singing. The Reich electrical recordings issued in the United Kingdom are as follows:—

- HMV B 2947 *Canaries in Song* (these seem genuine and not pseudo-nightingales)
- B 3779 *Chorus of Woodland Birds singing to "Forest Murmurs"; 2 parts*
- B 3958 *Hawaiian Memories* — Canaries singing against Hawaiian Orchestra
Woodland Birds' Morning Greeting

While the first two have been in the author's collection for over 40 years, the third record has always been elusive, suggesting the public had had enough, and failed to buy it.

Not so Brunswick's *Golden Bird*, a canary singing to 'Birds and the Brook' and 'The Canary Polka', a record from the end of 1930 which had a wide demand and is still found among the secondhand heaps. (British Brunswick 1008, later 01008). Decca also issued a Polydor under the number PO 5003 of canary song by cocks and hens bred in 1928, and these may well have come from Karl Reich.

The popularity of the budgerigar, or love bird as it was once known, in the fifties, brought two 78's from Decca:—

- F 10297 *Sandy Paul; Beauty Metcalfe*
- F 10662 *Joey the Chatterbox, 2 parts*

which had brief popularity. The listener is offered a bird talking as if with a beak full of birdseed, and it soon palls with repetition; like Nixa's Singing Dogs, these records are not hard to find, but a momentary novelty.

In the later 1920s until perhaps the first year or so of the 1930s, it was the custom of the B.B.C. to interrupt late-night dance music (10.30 to midnight) to take the listeners over to woods near Beatrice Harrison's home at Oxted, not so very far from where this is written. There the nightingale sang, encouraged by Miss Harrison on her cello; Elgar had written his Cello Concerto for her. She was undaunted about going down to the woods in the late evening with her instrument to serenade the bird into song, and The Gramophone Company started issuing recordings in July 1927. The first one was:—

- B 2469 *Nightingales and Dawn in an Old-world Garden*

Both these sides, though recorded in the Oxted garden, did not include Beatrice Harrison's cello. The next record did, however:—

- B 2470 *Nightingales singing, accompanied by Londonderry Air*
Nightingales singing, accompanied by Chant Hindoue

And these were followed soon after by:—

B 2853 *Nightingales singing*, accompanied by Songs my Mother Taught Me
Nightingales and Church Bells — a Summer Night Idyll

A composite record issued in 1930 was much acclaimed, and although such a recording could easily be put together today, for its time it was considered an achievement. This was:—

B 3345 *Daybreak on a Surrey Farm*
In a Village Churchyard — an Eastertide Idyll

Miss Harrison's cello was not featured on these sides.

Gerald Moore in his book "Am I too Loud?" (Penguin paperback) describes a visit to the Harrison family's home near Oxted, where a menagerie was kept, not only quantities of noisy dogs of all sizes, but budgerigars, canaries and parrots and two crocodiles in a tank in the dining room, and he wonders how all the noise that these animals used to generate was kept to the background as Beatrice Harrison played in her garden of nights, to induce the nightingales to broadcast. Eventually she took advantage of the publicity the nightingale had brought her and its outline appeared in the corner of her concert posters.

Those who live in or travel in parts of southern Europe in the Spring will agree to there being "a nightingale in every bush", as Lawrence, travelling in Lombardy, testified so many years ago, but the spread of towns and motorways in the south of England — where the nightingale visits briefly every year — has now made finding it more difficult. Dated though they are, it can still be enjoyed on the three records already listed, and on the *Daybreak on a Surrey Farm* disc. These were all most successful, are quite easy to find still, and one or two lasted in the H.M.V. catalogue until 1958, so more recent pressings are still possible.

At least once in a lifetime most of us experience a piece of occupational good fortune which enhances the reputation, or the pocket, or provides a scoop. This last happened by chance to a B.B.C. technician who went into the woods on the night of May 19th 1942 to record nightingales; not only did he get the bird song, but as a bonus the contrast of the noise of hundreds of R.A.F. bombers setting out overhead on a bombing raid on Mannheim, and by arrangement with the B.B.C. this was released on H.M.V. B 1016.

With television and the tape-recorder carried by shoulder strap it has all become too easy; perhaps the public is blasé, as there are few commercial bird records to be bought these days, the very occasional one available through a specialist source, and it's now 30 years and more since naturalists went out with the wax or acetate recording disc hoping that a bird would burst into 3½ minutes of gorgeous song as soon as the recording stylus was lowered.

Letter to the Editor

THE PLAYING TIME OF 33 1/3 R.P.M. RECORDS vs. 45

Reading Ian Cosens' interesting article on Sound Reproduction, Part 3 (Hillandale, October 1978), I cannot agree with his remarks that "The 45 r.p.m. remains an unnecessary anachronism: a 7-inch record playing at 33 1/3 r.p.m. would fulfil the same function with no practical disadvantage."

There are many variable factors in record cutting, all somewhat interdependent; recorded level, lines per inch (pitch), depth of cut, bass level compared with mid-range level and, most important for top-response and freedom from distortion, the linear speed of the disc under the needle at any given radius. Other factors involved include tracing distortion, pinch effect, radius compensation, groove shape and land/cut ratio.

I will not attempt a full mathematical exposition of the subject, which has been done by several investigators in the past, but will give a few of the known empirical facts.

Firstly, consider the inner diameter of 78's. This normally ranged from about 4 inches down to just under 3 inches for Broadcast and similar cheap records. One has only to consider the poor tonal quality of these at the innermost grooves to appreciate some of the difficulties.

Microgrooves and slower speeds obviously contribute to longer playing time, but both the maximum level and the groove depth are limited for any pitch, even when all the possible cutting area is used. Frequently, some bass-cut is resorted to for even fine l.p. work – possibly some compression and limiting, as well.

7-inch records, therefore, have these limiting characteristics:

Outer playing diameter: 6½"

Inner playing diameter at 45 r.p.m.: 4¼"

Inner playing diameter at 33 1/3 r.p.m.: 5"

Playing margin: 1 1/8"

Playing margin ¼"

As playing time = margin x pitch over r.p.m., it can be seen that, for any given pitch, the 33 1/3 record has 10/11ths the playing time of the 45. Vari-groove spacing (where the pitch is automatically coarsened for loud passages and diminished for quiet) would give substantially the same benefit in either case.

Therefore, the benefit of the 33 1/3 r.p.m. speed applies only on discs of 10 inches diameter or more, while deterioration of sound quality confines the 7-inch 45 r.p.m. disc to a maximum playing time of about 7½ minutes. The gap was filled, more or less, by the 10-inch l.p., and it is a pity that they are no longer on the market.

Barry Raynaud

Great Improvement in The "Seymour" Sound-Box

1912 Model beats the record. Price only 12/6. Adaptable to all Machines. Weight Reduced and Volume Increased. We are getting golden opinions with every post. Send for our illustrated lists of tone-arms, reproducers, diaphragms, needles, and various other
: :: :: specialities. :: ::

SEYMOUR MANUFACTURING CO.,
KELVIN HOUSE, 1, Richmond Crescent, Barnsbury,
London, N.

From "Sound Wave", October 1912



Sidney Carter has kindly lent us this snapshot of Felix Sykes, the Society's original recording secretary.

Review

SOUNDS VINTAGE – A magazine published bi-monthly from 28 Chestwood Close, Billericay, Essex, England. Annual subscription £5.80, airmail £6.80.

It seemed only a matter of time before a glossy magazine devoted to the wire-less set and phonograph-gramophone collecting fraternity appeared, and the January/February 1979 issue has come along.

As a month for publication January could not have been less promising to the editorial staff, unexpected bitter weather and industrial inaction and picketing in various trades, including paper.

Although in the twenties, I remember my father sitting up in the early hours of the morning trying to listen to a relay from America on the family crystal set, there was never an inherited affection for wireless, in fact the complexity of wires in the wire-less have always been a fence to my enthusiasm, and it has had to be the simplicity of, and freedom of choice on the gramophone and phonograph which won.

Therefore, although there was a tendency to turn over at the wireless pages of **SOUNDS VINTAGE**, it cannot be denied that these will appeal to the enlightened nostalgist (if there be such a word), with low resistance for the grid bias, the interchangeable range block, regenerator unit, Writtle, 2LO, and all that world.

Our friends the phonograph and gramophone are given about half of the magazine, starting with an article on 78s by Brian Rust, and on Phonographs and Gramophones for the Beginner by our Chairman – as it should be. Christopher also covers the talking machine sales in the London auction houses, and this may become a regular feature; Howard Hope contributes a splendid article and photographs on two coin-slot Columbias. There are perhaps seven main articles and quite a lot of shorter contributions, letters to the editor and so on. Advertisements large and small, For Sale and Wanted, will no doubt be a regular feature, and a few old-time adverts are reprinted for those who wish they were back in 1936 with today's income and knowing what they know today.

There are already two bi-monthly phonograph-gramophone magazines publishing in the United Kingdom, and both on the lookout for regular quality material, so will there be enough to go round? Perhaps the entry of this third, and glossy magazine, will cull new essays from those at present holding back on the edge and fearful of jumping in.

Without knowing what the new magazine has for us in the year ahead, many have chanced their £5.80 knowing "they can't go wrong for the money"; members are asked to give such a venture their support if they can, and perhaps one day it will be on every bookstall, and our Society will benefit from its prosperity.

The editors, Norman Stevens and Colin Riches were formerly editor and news editor of *Practical Wireless*, and the Society wishes them well in rearing the new youngster.

George Frow

The Body and Soul of the Gramophone

(THE CASE FOR THE DEFENCE OF THE CLOCKWORK ACOUSTIC)

PART 7 – THE MAIN TYPES OF SOUNDBOX CONSTRUCTION

While the mechanical action of all soundboxes is basically the same, there are two main categories of stylus-bar mounting: the tension spring and the pivot.

Tension spring mounting. Most of the earlier soundbox designs were of this type, with the stylus-mount held by tensioning springs against a pair of razor-edge fulcra on the soundbox body. This was done in one of several different ways.

In the cheap designs, the most common form of suspension was by a pair of short helical springs. These are found on either side of the needle-holder, below the stylus-mount. A screw passes through each spring, through a clearance hole in the stylus-mount and into the soundbox body, so that the spring, compressed between the stylus-mount and the head of the screw, holds the former firmly against the fulcra. It is not easy to adjust the stylus-bar into the correct position. When they are correctly adjusted, these soundboxes can produce quite good results, but the tone is often not as good as it might be because of the damping effect of the springs, which have little resilience. (See Fig. 1)

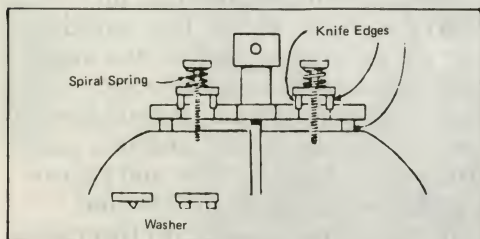

Fig. 1. An improved form of helical-spring pivot introduced by Perophone in 1927. A washer with its own pair of fulcra is inserted between the spring and the stylus-mount or pressure-plate.

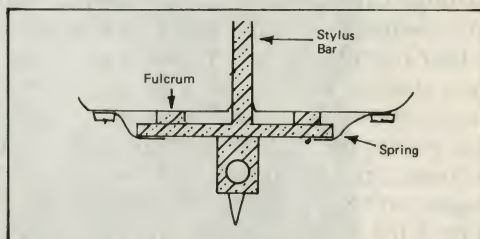

Fig. 2. Form of mounting used on Decca Telesmatic.

Another arrangement, employed on Decca Telesmatic soundboxes, has a spring clip screwed into the body at each end of the stylus-mount. Tightening the screw brings the clip into firm contact with the mount and thus presses the latter against the fulcra. This type is not easy to adjust; the clips have to be juggled into position so that the stylus-bar is correctly aligned before being secured to the diaphragm. In my opinion, this design does not allow the stylus-bar a great deal of freedom, and so bass response is restricted. I have got some quite good results from a Telesmatic soundbox by inserting a thin slip of rubber between the clip and the mount, allowing greater freedom of movement. (See Fig.2)

(In fact, Telesmatics seem to have had just such a slip of rubber originally. The design was merely a simplified form of that found on other Paillard-manufactured soundboxes, such as the Apollo Senior and Sylvaphone. These had similar clips, with rubber pads, but mounted at right-angles, like the Exhibition tension springs —Ed.)

Possibly the best type of spring suspension is that found on the Exhibition, H.M.V. No.2 and similar good quality soundboxes. Here, a short strip of spring is screwed to each side of the stylus-mount and protrudes at right angles, one to the front and the other to the rear. The outer end of each spring is attached to a corresponding projection on the body by an adjusting screw with a lock-nut. Adjustment of the stylus-bar is easy, as tightening one spring can be counter-acted by tightening the other and greater resilience is possible while the mount is still held firmly against the fulcra. (See Fig.3)

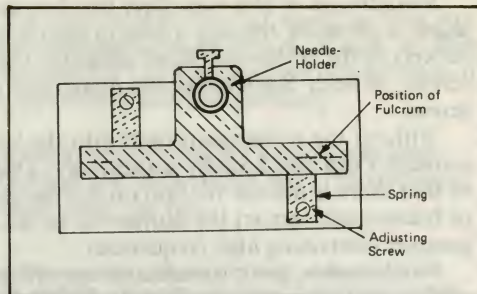

Fig. 3. Flat spring mounting (Exhibition etc.)

On a sharp, well-shaped fulcrum there is no chance of chatter with spring systems such as this, and adjustment is not affected by changes of temperature. A disadvantage is that the extra tension from the springs tends to curtail base response.

(Which is perhaps why H.M.V., for example, adopted pivots when electrical recording increased the amount of bass to be responded to -Ed.)

Another form of spring mounting uses a flat piece of spring acting as a hinge, like a pendulum suspension. This was used by Thorens and Paillard on late designs such as the Prima-phonc and Maestrophonic (and also on the 'Trade-Mark' Gramophone -Ed.). It is effective, but unadjustable.

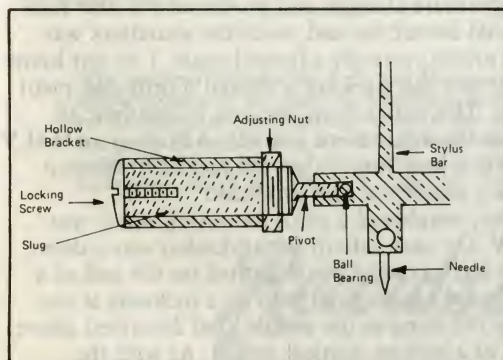

Fig. 4. Cross-section of pivot on H.M.V. No.4 soundbox (Nos. 5a and 5b are similar).

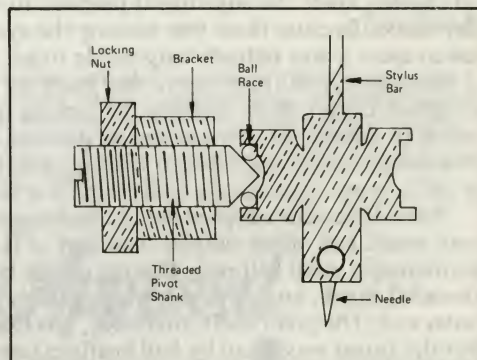

Fig. 5. Cross-section of Columbia ball-bearing pivot.

Pivot Mounting. Soundboxes with pivot-mounted styli were about as common as those with tension springs. In fact, towards the latter half of the clockwork-acoustic era, pivot-mounting became more common and more finely developed. The idea was to eliminate the extra restraint springs inevitably place on the movement of the stylus, and so produce a fuller tone with less strain on the walls of the groove.

Soundboxes of this type have two brackets protruding from the bottom. A cone-ended shank is threaded through a hole in each bracket with the conical points engaging corresponding sockets in the stylus-bar. When adjusted, the screws are locked in position by nuts or locking-screws, or both. Sometimes, the points are on the stylus-bar and the sockets in the ends of the screws.

Without the refinements built into the later H.M.V. and Columbia models, no pivot-mounted soundbox can ever be fully satisfactory. This is because it is very difficult to adjust the pivots so that there is neither friction on the one hand nor free-play on the other. The slightest degree of friction will restrict the movement of the stylus and cause record-wear, particularly over passages containing high frequencies.

Furthermore, pivot soundboxes are affected by changes in temperature. After adjusting one of these soundboxes to a nicety before fixing the diaphragm, I have found that when the heat of my hand has worn off, the stylus has become unduly stiff due to the contraction of the housing. Adjust such a soundbox in summer, and it will go stiff in winter. Get it right in winter, and it will work loose in summer. This is minimised if the pivots have good, sharp points.

The H.M.V. No.4 was the first soundbox of that make to use pivots instead of springs. These pivots were of a unique form, and were also fitted to the later 5a and 5b. The system was designed to reduce friction to an absolute minimum.

Instead of being conical, the pivots are of parallel diameter, with square ends bearing on a tiny ball-bearing in the bottom of a hole bored in a cross-bar on the stylus-bar. The pivots are formed on the end of a smooth-sided 'slug' fitting closely, but slideably, in a hollow bracket sweated on to the body. Adjustment is by a lock-nut at the inner end and a mushroom-headed screw at the outer. When the screw is removed, a screwdriver-slot in the end of the slug enables the latter to be turned in the locknut. (See Fig. 4).

When I was discussing H.M.V. soundboxes with a shop assistant before the war, he told me that, at the factory, the two pivot-mounts were set finely in a certain position which eliminated all chatter, made the adjustment immune to temperature changes and produced the best tone definition. Because there was nothing the eye could detect, he said, once the soundbox was taken apart it was virtually impossible to get the pivots correctly adjusted again. I do not know if this is true, but I have found that both the tone and the tracking is altered if only one pivot is turned slightly after releasing the locking screw. This varies from one box to another; all seems to depend on how one exerts pressure while the adjustment is made. Adjusting an H.M.V. box is very tricky, and hard to explain, and it takes a long time to get the feel of it. When it is right, in my opinion, the H.M.V. No.4 is the best soundbox ever produced.

When Columbia adopted metal diaphragms, they employed a pivot mounting which was very sound and rather simpler than that of H.M.V. On each side of the stylus-bar was a sleeve containing a small ball-race. Bearing on the latter was a conical pivot formed on the end of a threaded shank, housed in a correspondingly-threaded bracket and held by a lock-nut at the outer end. The pivot itself, therefore, was exactly the same as the simple kind described above, but the thrust was taken by ball-bearings instead of a hollow, conical socket. As with the H.M.V. design, the ball-bearings enabled the pivot to be screwed home without undue friction resulting. (See Fig.5)

(Two other variations on this theme are worth noting: The Orthophonic soundbox (which appeared over here briefly as the H.M.V. No.5), had parallel-sided pivots which were magnetised and were surrounded by a ball-race, the magnetism causing the balls to cling to the shank regardless of expansion or contraction due to temperature changes; and the H.M.V. No.23/Columbia No.24 soundbox, which combined the features of its parentage and had a ball-race around the pivot as well as a ball in the centre. Whether any magnetism was involved, I do not know. —Ed.)

Diaphragms. Looking at results obtainable from mica or metal diaphragms, I feel personally that the best tonal balance is obtainable from mica, although there is little to choose between

them. Metal diaphragms do have the mechanical disadvantage that they can easily be bent out of alignment. (H.M.V., Columbia and other well-designed soundboxes have checknuts or other configurations built in to prevent the stylus-bar being pushed too far out of its normal range of movement.) Mica is more robust, but nevertheless can crack if handled carelessly.

The main body or shell. This varies in construction; many of the cheaper soundboxes were made in one piece, and the diaphragm is inserted through the front of the box. The stylus-bar is then attached, and finally the front gasket is tucked under the rim.

(I prefer to insert the front gasket before attaching the stylus-bar, especially with spring-tension designs, as the position of the diaphragm will recede slightly when the insertion of the front gasket compresses the rear one. The stylus-bar should just touch the diaphragm, before the fixing screw is turned home, when it is in its mean position. —Ed.)

On some soundboxes, including the Columbia No.6, a threaded ring on the front of the shell unscrews to release the diaphragm. (This model is pivot-mounted and has a 2¼-inch diaphragm). On others, a ring is held in place by screws, or there is a mask over the whole front which also serves to retain the gaskets. On most soundboxes, however, the back-plate can be removed by undoing three or four securing screws. This means that the diaphragm can be removed without interfering with the stylus mounting. Most H.M.V. and Columbia models are of this type, although on some H.M.V. No.4 and No.5a and 5b boxes the back is found to be seized on, and cannot be removed without breaking. Many years ago, the people at the Gramophone Exchange told me that H.M.V. had begun making back-plates to fit only after the shell had been heated. There was then no way of removing them except by re-heating, so that replacing diaphragms was somewhat hazardous, and one would do better to buy a new soundbox — good for trade, of course! A further complication with the No.5 boxes is that the diaphragms are soldered to the stylus-bar.

E.J. Goodall

(The problem with the No.4, 5a and 5b boxes is that the back-plate is made of a die-cast zinc alloy which swells over the years. Sometimes it actually cracks the brass shell on the 5a, which can lead to a split diaphragm, and certainly distorts the shell so that the pivots are out of alignment. This does not apply to early No.4s, which have brass backs, and I suspect that later 5b's were made with a greater clearance to avoid the trouble. The last No.4's had diecast shells as well, which swell (and sometimes crack) with the back, upsetting the pivots. —Ed.)

Records on Approval.

Let me send you an assorted parcel of discs to try over "On Approval." My system is an original one and offers advantages over and above all others. Why not send for my "little folder" and hear more about it. Send to-day.
:: Lists free anywhere. ::

Any **DAWSON GOODEY.** Any
Make **24, LEGARD RD, HIGHBURY, LONDON.N.** Quantity

From "Sound Wave", September 1915

People, Paper and Things

BY GEORGE FROW

The year 1979 marks the centenary of the electric lamp demonstration by Edison on October 21st, but our Newcastle member Phil Bailey has drawn my attention to a recently published booklet on a fellow "Geordie" Joseph W. Swan, who demonstrated an incandescent filament lamp some months earlier on February 3rd, 1879. The subdivision of electric power into numerous individually controllable lamps had occupied the attention of physicists during the last century, and the carbon arc lamp, although suitable for the illumination of large areas, had considerable limitations, but is still used in some searchlights, spotlights and cinema apparatus. Many of the experimenters with early incandescent lamps from 1820 used platinum coils or slender carbon rods in a vacuum, and had shunned the filament as short-lived. A goodly number of carbon lamps were developed, and patented, between 1820 and 1878, including one of Joseph Swan's of 1860 which used a carbonised paper strip in a vacuum and some progress was made up to Bonliguire's model of 1876. Swan's 1878 lamp used carbon wire glowing in a tear-drop glass globe. On Feb. 3rd 1897 Joseph Swan lectured on the subject of the electric light at the Philosophical Institute, Newcastle, the chair being taken by the engineer Sir William Armstrong. At the meeting at which his electric lamp was demonstrated, Swan read out a telegram he had received the previous October from Thomas Edison, describing the forthcoming installation of electric light in New York, centred on Nassau Street. However it was another year before Edison was able to demonstrate a successful lamp. Obviously they were treading on one another's heels, but this is hardly the magazine in which to pursue this line further; those interested can read up Edison's work in Francis Jehl's "Reminiscences of Menlo Park" — parts 2 & 3 are probably obtainable from Dearborn — or the much more recent "The Incandescent Light" by Floyd A. Lewis, which may be bought through the Thomas A. Edison Foundation.

Later of course, after the customary litigation, Edison and Swan combined in Great Britain and had the monopoly of electric lamp manufacture until 1893, but no record has been seen of their ever actually meeting. Thanks to Phil Bailey for reminding us of this centenary.

Two books have come my way with record connections which are worthy of mention to members, one recently published, the other which has been loaned, appeared 53 years ago, and is not easy to find now. The new one is a biography of Will Hay, who died thirty years ago; this is the first appreciation of the life of this surprisingly complex though brilliant man, who amused us on the halls, on the wireless, and from 1934 to 1943 on the films. Hay with his Scholars in the school sketches made several records on Columbia (9689, DX 558, 5695 and FB 1540) spread over ten years, and with his film partners Marriott and Moffat on FB 2040, and in excerpts on VS 4 and DB 1330, and although the school sketches were brilliant and models of timing, they have a dry unamusing effect when played "cold", and would today have been given "audience-participation" — whatever that means. Anyone wanting to start a Hay record collection may have my spare copy of 9689 for one of DX 558. This generously illustrated book is called "Good Morning Boys", by R. Seaton and R. Martin, and is published by Barrie and Jenkins at £5.95. The foreword is by Eric Morecambe.

The second volume is Lt. Col. J. Mackenzie Rogan's 1926 autobiography called "50 Years of Army Music", and published by Methuen. Rogan was in the army for an extraordinary span from 1867 to 1920, much longer than anyone would hope to do these days, and was conductor of the Coldstream Guards Band from 1896 to 1920, later in his career becoming senior conductor to the Brigade of Guards. He claimed to be the oldest serving officer in France when he several times toured the Western Front with the Band from 1916 to 1918, and seemed to be close to the fighting for a band conductor. His records with the Band for the Gramophone Company are to be counted in their hundreds — oh, yes, someone will do a discography one day — and they turn up in just about all collections and secondhand heaps of records of that era. The book is by no means a literary masterpiece but vividly describes a hard mid-Victorian military life that now seems so remote, comrades dying of cholera in India, a drumming-out ceremony, the public hanging of a soldier in the regiment, and so on, but as Rogan went up in rank he was fortunate to be on approachable terms with Kings Edward VII and George V, describing their musical preferences and insistence on correct ceremony and protocol. What the record collector will seek in vain in this book is any reference to recording,

and I have referred to this with other autobiographers, Harry Lauder for instance. It seems amazing that these prolific recording artists of eighty years ago so rarely chose to include their experiences and inner feelings at approaching what then was a wonderful medium; Peter Dawson was one of the exceptions, in "My Life of Song", mentioned previously.

One who never hesitates to express himself over recording and recordings is Frank Andrews, and he has written the lengthy introduction to the reprinting of Sydney Carter's listing of the Blue Amberol cylinders. "Blue Amberol Cylinders" is now published by Ernie Bayly, but may be bought through the Society for £5 — or £4 for members. Originally this was in three volumes and covering all known Blue (and Purple) Amberols issued anywhere. Like all first editions the original books contained a number of excusable errors, but by making new plates from these books, these errors are repeated and of this the reader should be aware; perhaps a correction sheet could be inserted. Frank Andrews' Introduction gives a very complete history of the Blue Amberols, especially as received in Great Britain, and he has gone some of the way towards dating their release months by giving the British 23000 series, but those of the United States and the other 23 countries will one day have to be tackled by somebody. Those Blue Amberols made by the direct recording method before the Edison fire of 1914 were the finest recordings made anywhere before the electrical process came in in 1925, and after 1914 those Blue Amberols dubbed from Edison Discs by the horn-to-horn method disappointed the discerning, but this was just a cost-cutting move on the Company's part.

In corresponding with member Werner Muller, Schulhaus Obstgarten, 8712, Stafa, Switzerland, he asks if I can put him on to an Ediphone or Dictaphone which he requires for school purposes, and he stresses that such a machine must have recording and reproducing styli. I pass him over to the membership with the hope that someone can help. Central Europe is a difficult and dear place to find veteran machines, let alone something more recent such as this, and Werner Muller is not anxious to pay oil-sheik prices.

The death of Wee Georgie Wood in February at the age of 83 leaves us with no other stars of the pre-Great War Music Hall. He started very early on the stage, was a star by the age of 10 and never grew to more than 4ft 9ins. His high voice enabled him to perform in sketches as the cheeky boy, and his name became a household word before 1914, and has been ever since. Some years ago now the Society, not knowing his views on abstinence, invited George Wood to address them at the "White Swan" public house in the City, but finding he was expected to talk on licensed premises, he refused to go on, and left, which was a pity as he had known all the great artists of the music hall, and once started could reminisce for hours. He made a few records of his mother-son turn with Dolly Harmer, but these were nearly all on minor labels and tend to be overlooked by collectors.

We hear with regret that the *American Phonograph Journal* will not be published further. Readers will recall that in the December issue of *Hillandale News* our members were asked to rally to support this quarterly journal, a work undertaken by Dr. Phillip Petersen and friends in California, and reaching a commendably high standard. Like *The Times* it is much missed, and may we hope that someone some day will try and resuscitate it.

Instituted for the Purchase, Sale, and Exchange of Superior Disc Gramophones and Records.

THE GRAMOPHONE EXCHANGE

Keep every Title actually in Stock in all the following makes:—

Columbia, Regal, Rena, De Luxe, Columbia Opera and Celebrity Series, Zonophone, Zonophone Opera, Meister, and Fonotopia Records. Large Assortment of Pathe, Odeon, His Master's Voice and other good makes.

THE FAMOUS ASTRA SOUNDBOX, 15s., Post Free.

Over 15,000 Records and 100 Machines always in Stock. Any Record, Machine, or Accessory sent per return carriage paid, on receipt of remittance, and willingly exchanged if not satisfactory.

BEST SWISS MOTORS FROM 30/- TO £5 15/-

GRAMOPHONES AND RECORDS EXCHANGED.

TERMS ON APPLICATION.

29 & 31, NEW OXFORD STREET, W.C.

SHOWROOMS FIRST FLOOR

The Firm with the Big Reputation.

(OPPOSITE MUDI'S LIBRARY).

From "Sound Wave", September 1915

Book Review

SIR DAN GODFREY and THE BOURNEMOUTH MUNICIPAL ORCHESTRA, published by The Vintage Light Music Society, 4 Harvest Bank Rd., West Wickham, Kent, England. Price 65p.

To those who have passed middle age, the name of Sir Dan Godfrey is synonymous with The Bournemouth Municipal Orchestra of one's youth, in fact he was the outstanding member of an intensely musical family, nearly a dozen of whom became conductors of leading military bands, and others were to make their name in music as players or composers. Godfrey's father and uncle were the first and second army bandmasters to receive a commission.

A booklet on Sir Dan Godfrey and The Bournemouth Municipal Orchestra has just been published by The Vintage Light Music Society; it is a greatly enlarged and glossy version of a similar one published some years ago, and it is hard to think of any further details on the subject that might have been included. Dan Godfrey started the Corporation band at Bournemouth in the nineties after his father declined, and from that developed a good orchestra from which he retired in 1934; today, as The Bournemouth Symphony Orchestra, it is famous among our national orchestras.

With the catholic range of musical tastes that our members have, this booklet should appeal to quite a number; there are extracts from concert programmes of those days, from the Radio Times, and quite a number of photographs, some of which have not reproduced well. Recordings associated with Sir Dan Godfrey and the orchestra – sometimes together and sometimes going it alone, are listed, and readers of over 55 years should experience warm nostalgia as the names come back. This is a useful signpost for anyone setting out to become a record collector, or one already established, whatever their taste, because although he purveyed essentially the lighter kinds of music, Godfrey moved about among the composers and conductors of his day and he will one day merit a revival of interest. Sir Dan's autobiography "Memories and Music" (Hutchinson 1924) can occasionally be found in secondhand bookshops, but this compilation by Stuart Upton continues the story until Sir Dan's retirement and after, offering good research on scarcely trodden ground. The booklet is recommended at the price.

George Frow

Dark	'Business as Usual'	Blue
<p style="font-size: 2em; margin: 0;">We never Yield— Keep the Edison Flag Still Flying.</p> <p style="font-size: 0.8em; margin-top: 10px;">Agents in all parts.</p>	<p style="font-size: 0.8em; margin: 0;">Particulars free. Write for terms to-day.</p>	
Amberol	Arcade Emporium, NORTHAMPTON.	Records.

From "Sound Wave", September 1915

Report of the London Meeting at the Bloomsbury Institute on 7th Feb. 1979

TALK GIVEN BY FRANK HOLLAND OF THE NATIONAL MUSICAL MUSEUM

When the programme was advertised in the December magazine it was said that Frank has a good line in chatter. This certainly proved to be the case on the evening, where a gathering of about 20 people were captivated by his talking. The programme started off with a slide display of various aspects of his museum while we heard several machines on a long playing record as they made their appearance on the screen.

We heard, among others, the WurLitzer which came from the Regal Cinema in Kingston; The Imhof & Muckle Orchestron from Imhofs in New Oxford Street; the Violano Virtuoso, by the Mills Novelty Co. (this machine plays the violin with piano backing on 110 volts d.c. and was the brainchild of a certain Swedish engineer in 1904-7, a man who was well ahead of his time on electromagnetic technology); The Hupfeld Animatic Clavist Sinfonie Jazz Piano (upright) Model No.9 (as complicated as the name suggests, with an enormous range of percussion gadgets to support the piano theme); and we also saw and heard a few player-pianos, which had different roll mechanisms or were special in one way or another.

The slides were interspersed with tales of the leaking roof and other problems Frank has suffered in his 14 years at the museum.

After the interval, we heard a few words from Eddie Ferguson, in London for a few days, about himself and the forming of the East Fife Branch in conjunction with Jim Goodall. We then went through some memories of a recent trip that Frank had been on to New Zealand and Japan. These were illustrated with pictures that were passed round, and he demonstrated how the Duo-Art piano roll mechanism works. We concluded with a 78 record of a piano roll recording with a J.H. Clapham. This record had seen better days and did no justice to the Artist. However, the whole evening was a great success and we look forward to having other visiting speakers to our meetings in the not too distant future. Thank you Frank for a good show, and thanks also to Len Watts who played the records and kept things working properly.

For those who missed the programme you can see Frank "at home" from April 1st and subsequent Saturdays and Sundays through the Summer. The record used was "Mechanical Memories" (GH 625 Pye), recorded at the Museum.

London Reporter



6 Records (10 in. DOUBLE-SIDED) for 9s.
ALMSCLIFFE'S GREAT OFFER.
Your own selection of twelve titles sent post free. Any record that does not come up to expectations, willingly exchanged.

12 Selections post free for 9s.
— Write for List. —
CYRIL ALMSCLIFFE,
398, St. John Street, Clerkenwell, E.C.



CLIFF.

From "Sound Wave", September 1915

Report of a Meeting of the Recorded Vocal Art Society

at the Bloomsbury Institute on Jan. 31st 1979

The R.V.A.S. is run by Gordon Bromly and his wife Deborah. At this particular meeting, I saw that several members had brought a record with them, and each was given one half of a raffle ticket. The other half was put into a jar, to be drawn as the meeting proceeded.

The records were all vocal, of course, but covered a wide range; artists included Walter Hyde, Bettendorf & Melchior, Schlusnus, McCormack, Tauber, Dawson, Battistini, Austral and Tudor Davies, Alfredo Kraus and Lotte Lehmann.

Gordon acted as link-man, playing the records as required, and the members themselves made comments on their choice. Gordon had to make some rapid changes on the turntable as he went straight from 1905 G & T to 1956 microgroove. The whole thing was very lighthearted and enjoyed by all.

If you are at all interested in vocal recordings, you should make a point of going to a meeting — you will go again and again!

Dave Roberts

"NEWTONE" Record Reviver and Preserver gives new life to old Records (Cylinder or Disc), increases their durability by diminishing the friction between reproducer and Record.

OLD RECORDS

when thoroughly cleaned with **"NEWTONE"** are refreshed and **MADE NEW.**

Price 6d. per bottle from your dealer, or Post Free, British Isles 7d.; Colonies 10d.; Abroad 1s. From Proprietors **JAYSEE Ltd., LEITH YARD KILBURN, London, N.W.** One bottle will renovate over 100 Records. Full instructions and sheet of testimonials with each bottle.

☛ 4/10 Reward if the testimonials are not genuine and unsolicited. ☛
(Stamps not accepted for Foreign or Colonial orders. Postal orders only.)
Dealers supplied direct. Established 19 0.

IN **DEVONPORT** BUY

SCALA RECORDS

FROM

W. FARRELL

40, Marlborough Street,
who has every Number in Stock.

CHANGE THE MOTOR, SIR!

Makes all the difference in the world. Your old Records will play like new again. Your New Records will shame your neighbours!

1913 MODEL "4" MOTOR—Double-Spring, 12-in. Turntable, all Fittings, Speed Indicator. Price 24/6; 5/- for old Motor.

1913 MODEL "6" MOTOR—Double Vertical Springs, Improved Wind, 12-in. Turntable, all Fittings. Price 30/-; 5/- for old Motor.

1913 MODEL "8" MOTOR—Double-Spring, 12-in. Turntable, Plays Eight Records One Wind. Price 40/-; 5/- for old Motor. 2/- extra for fitting to Cabinets.

Approval or money back as usual. Expert repairs of every description. Any Fittings made. Testimonials galore.

LLOYD THOMAS'S MOTORIES, HORNSEY, N.

IN **HOLLOWAY** BUY

SCALA RECORDS

FROM

BISHOP'S,

460, Holloway Road,
who has every Number in Stock.

From "Sound Wave", September 1915

The Cut of the Sapphire Disc

AND ITS RELATION TO THE SIZE OF THE SAPPHIRE REQUIRED FOR REPRODUCTION
BY LEON BURGOYNE (1911)

The public appreciation of the Pathe sapphire disc records soon caused other firms to appear in the field, with the result that we now have the Pathe, Aspir and Ebonoid, and till recently the Musogram. There is one important point to be remembered when considering the question of the reproduction of these records, viz., the fact that each of the above firms has adopted a different pitch — i.e. number of grooves to the inch — in recording. It seems a pity that some standard has not been chosen like that of the cylinder records, which were without a single exception recorded at the 100 threads to the inch standard, not taking into account, of course, the new Amberol and Crystol, which run 200 to the inch. For this state of affairs as regards the phono disc I think we must partly blame Messrs. Pathe Freres, as from the very outset they adopted two different cuts for their 8½ and 11 inch records respectively. Owing to the general clamour on the part of the public for longer records, a very justifiable desire, the new comers in the phono disc industry very naturally decided to fulfil this wish as far as possible. Now this could only be done in two ways, either by increasing the size of the disc, thus rendering it more fragile and at the same time more costly, or by recording at a finer pitch. Naturally this latter course was adopted when it had been conclusively proved — as witness the Amberol cylinder record — that good recording could be accomplished at as fine a pitch as 200 threads to the inch. Unfortunately, as I said before, no standard has been chosen, with the result that we now have about half a dozen different kinds of phono discs, each one recorded at a different pitch.

I cannot help thinking that a good deal of damage must be done to manufacturers through this confusion in the following way.

Supposing a person has just bought a Pathephone with the regular ebonite sound-box as supplied with the machine. We will presume he has purchased at the same time some Pathe 11 inch discs. He tries them over, and is well pleased with the result. Later on he sees, say, Musogram long-playing records advertised. He sends for two or three to try, and is forthwith dissatisfied with same. He immediately condemns the records and decides to buy no more. He has compared them, mind you, with the Pathe ones in his possession, and finds a great difference in the reproduction. The natural conclusion is that as his Pathe records play perfectly; it cannot be the sound-box which is at fault, it must be the records, the result being Musograms are immediately banned. If this customer had only known that Musogram records require a much smaller sapphire than Pathe discs and had used one accordingly, he would doubtless have had a very different opinion of the former. It must be said that Messrs. Pathe, by using a coarser pitch than any of their competitors, run no risk of having their reputation damaged by their records being played with the smaller sapphires used in the reproduction. The latter, as a small sapphire, will give an excellent reproduction with the coarser cut records, but the reverse by no means holds good, the reproduction of a finely-cut disc with a comparatively large sapphire being most unsatisfactory. The reason of this is not far to seek, and has often been explained to the novice through the medium of the talking machine journals, the explanation being that a small sapphire will get to the

bottom of the grooves in the record, so that every minute indentation is reproduced, whilst on the other hand a large sapphire in a finely-cut record will not be able to get to the bottom of some of the indentations, and thus a good many of the finer sound-waves are lost, the resultant reproduction lacking that clearness which it would otherwise possess. Now although I have said a phono disc can be played with excellent results by using a smaller sapphire than is necessary, we lost a certain amount of the volume thereby, but at the same time this is compensated for by the fact that the mechanical scrape of the record is also reduced, and a good many prefer to sacrifice some of the volume for the sake of this obvious advantage. A very erroneous idea seems to prevail that the amount of surface contact between the reproducing sapphire and the record has no bearing on the volume, the contention being that so long as the sapphire causes the diaphragm to move the full extent of the depth of the indentations the volume will be the same. Although in theory this might appear to be, as an actual fact in practice it is not. Fortunately the axiom can easily be proved by anyone by playing the same record with the same sound-box, but with two different sized sapphire needles alternately, one condition being observed, if the test is to be conclusive, viz., that the distance of the extreme point of the sapphire from the fulcrum of the stylus lever must be exactly the same in both cases.

There is no getting away from the conclusions to be drawn from this experiment, viz., that the amount of friction and consequent thrust between the sapphire and record determines the volume, other things being equal. It is not sufficient to merely agitate the diaphragm a certain distance to obtain great volume, else why is it that although we can cause a comparatively heavy vibration of a sheet iron diaphragm by holding close to its centre a strong electro-magnet connected to a rapid make and break arrangement, yet the sounds emitted are comparatively feeble compared to the sound which would be caused by the same amplitude of

vibration brought about by actual blows on the diaphragm. The theory of sound reproduction is a most complex thing, and in many cases it seems almost impossible to square theory with actual facts as proved by practical experiment.

In this connection I would like to set a curious problem, viz., supposing you take a slab of marble, the dimensions are immaterial. Now if we strike this ever so gently with a piece of glass or iron, say a glass marble, for instance, we notice it gives out a sharp, clear, high-pitched note. Now supposing matters were so arranged that the glass marble was mounted on the end of the stylus lever (the end usually fixed to the diaphragm) of a sound-box, and arranged in such a manner that every indentation of the record caused the glass to strike the marble slab. Under these circumstances we should undoubtedly get a true reproduction of the record from the marble slab. The question is what would the reproduction be like and what would be the theory involved, as although the marble slab would be to all intents and purposes a diaphragm, yet at the same time it could scarcely be said to vibrate in the usual sense of the term like the ordinary talking machine diaphragm.

Some might argue that the vibration of the marble striking the air causes the sound, but this would scarcely be the case, as I think we may assume that if the glass was made to vibrate without touching the marble slab gradually no sound would be emitted. I may say at once that I have not tried the above experiment owing to mechanical difficulties, so have no particular theory to expound in this connection. Apropos of this matter, I should like to know if anyone has successfully tried to reproduce a record somewhat on the lines above, viz., by so arranging the ordinary stylus lever that when at rest it just cleared the diaphragm by a fraction of an inch, the indentations of the record when in motion causing the lever to give a series of rapid blows on the diaphragm. I fancy if the experiment could be successfully accomplished the result would be a fairly powerful reproduction if a large diaphragm and a

combination of electrical and mechanical devices were used, the details of which are rather too complex to enter into here.

There is one important point which is very apt to be overlooked, and in most cases certainly is overlooked, when discussing the question of the cut or threads to the inch of a record, viz., the fact that whilst we might have a comparatively speaking, coarse thread, the thread of the actual sound grooves themselves might be very fine. This, of course, would simply mean that if we reduce the width of the sound grooves, i.e. by using a smaller recording sapphire, we can still keep the pitch of the thread the same, but the thickness of the well between the grooves will be increased by as much as the width of the groove is decreased. It follows from this, therefore, that for reproducing purposes it is necessary to use a sapphire which will fit the grooves irrespective of the distance between the threads.

For the sake of obtaining as much volume as possible and at the same time economising space the practice is to reduce the thickness of the walls between the grooves to a minimum, with the result, unfortunately, that the life of the records is lessened, as in time these fine walls are gradually worn away or broken down, more especially where too large a sapphire is used or a badly-tracking reproducer is employed. If a large sapphire is employed, what happens? Why, simply the weight of the reproducer is borne mostly by the two side walls of the groove instead of the bottom and sides of the latter. If a badly-tracking repro. is used, a considerable amount of side pressure is exerted on the walls. These remarks apply equally to either cylinders or phono discs, and it is for this reason that it is most important, if we wish to prolong the life of our records, to see that the repro. or sound-box, whichever it may be, works quite freely. Of course, with the Indestructible cylinder records at present on the market the above precautions are not necessary, there being practically no wear on the record whatever under these conditions. It seems most extraordinary, considering the various advantages which celluloid possesses, as to wearing and other

qualities, that the makers of the phono-cut records do not endeavour to utilise it in the manufacture of their records. The question of surface noise ought not to trouble them much if we consider how successfully this has been overcome in the latest Indestructibles (cylinders), and after all a vulcanite disc, be it sapphire or needle cut, may be very smooth running at first, but this condition of things does not last very long, as after a few reproductions the scraping noise begins to assert itself. The reason, of course, is that whilst the material may be very hard, it is also extremely brittle. Celluloid, of course, whilst being hard, is not a brittle substance. I believe the first Neophone discs were made of a thin facing of celluloid with a backing of cardboard like the Nicole records, but the surface noise was intolerable. This difficulty, however, as I have already stated, has been nearly overcome, and one fact we must not overlook is that the surface noise of Indestructibles does *not* increase with wear; in fact, the reverse is, if anything, the case, whilst, of course, as everyone knows, vulcanite discs get worn and worn with each reproduction until they finally become unbearable. We then string them on sticks like Chinese "cash" and hang them up out of the way until the day comes when we decide to dispose of our "Gramophone and quantity of records, as new!! To be sold cheap. No approval!"

I was speaking just now of the proper tracking of reproducers being essential to preserving the life of records, more especially the wax cylinders and in particular the new 200 thread type, and in this connection I cannot help remarking the ignorance often displayed by writers in the correspondence column of the talking machine journals. We often see the terms "floating reproducer" mentioned and comparison made between these so-called floating repros. (by which is usually meant the old Columbia and continental machine type) and the Edison type, as far as their tracking qualities are concerned, the assumption being, of course, that the latter is not a floating repro. Now if we examine these two types carefully we can easily see that there is

nothing to choose between them as regards tracking properties are concerned, and there will also be no getting away from the fact that one is just as much a floating reproducer as the other. In the continental type the whole weight of the repro. rests on the record and by means of a swivel joint it is capable of moving either laterally or vertically, the movement in both directions being, of course, limited.

Now in the Edison pattern, whilst the body of the repro. is a fixture, the sapphire holder is hinged on a weight, which latter is itself hinged to the body of the repro. in such a manner that it has exactly the same movements as the other type. The lateral play of the Edison type is limited by a pin rocking in a small V-shaped loop, whilst in the continental repro. this side play is limited by the swivel connection. Now although most writers seem to imagine that the latter type is the more likely to track properly, in my opinion the reverse is the case, for the simple reason that the V-shape of the limiting loop keeps the floating weight absolutely central when lifted off the record, with the result that when the repro. arm is let down the pin is left in a perfectly central position in the loop, i.e. the amount of side play is exactly the same to right or left. With the majority of continental machines, on the other hand, there is no self-centring device (which is a curious thing, considering the simplicity of it), and consequently should the machine be resting on a surface which is not perfectly level the repro. will swing over to one side when lifted off the record and, of course, when let down for playing its lateral movement in one direction will be practically nil, with the result that after a few turns of the mandrel the sapphire will give a sudden jerk across several of the record grooves.

There is one important thing to be remembered, however, and that is that no self-centring device is of any use unless we let the sapphire down on the *grooves* of the record and *not* on the smooth part that precedes the grooves. The repro. is almost certain not to track properly at the beginning if this precaution is not observed.

With the 200-thread records it is particularly important that the sapphire tracks freely if we wish them to wear well.

We have seen various opinions expressed recently as to the wearing qualities of these Amberols, but it is impossible to come to any satisfactory conclusion as so many things have to be taken into account when considering the question.

One critic, perhaps, favours loud band pieces.

Another favours quieter records.

Another has a liking for pieces with bells, whistling, piccolo, etc.

Another uses a so-called floating repro., which may be rather heavy, or another has a similar repro. which has a stiffly-working swivel arrangement.

Now all these different conditions will affect the wear of the record. It is for this reason that I am looking forward with some interest to the introduction next season of 200-thread indestructible cylinders, as we shall not have to worry ourselves about any of these things as regards the life of the record is concerned. To the "talker enthusiast" there is nothing so worrying as the feeling that every time a record is played the quality of the reproduction is impaired, with the result that our choicest records cannot be enjoyed to the full for fear of wearing them out too quickly. It would be a good move on the part of the manufacturers of the (four-minute) 200-thread indestructibles if they were to make the records the full length of the ordinary phono. mandrel, as a good half-inch or more could be utilised, thus giving us selections playing 5½ or more minutes. To the amateur enthusiast the indestructible record offers great facility for experimenting, as all sizes and shapes of sapphires, and also repros. of any size and weight, can be used without the record being in any way deteriorated. Whilst speaking of these records I might mention that a very good, clear, but comparatively quiet reproduction can be obtained by using a sapphire ground to a point, but not sufficiently sharp to scratch the surface. A sapphire this shape is bound to reproduce the minutest detail of the record, whilst

the surface noise is reduced to a minimum. I have tried this type of sapphire with very satisfactory results. It will be seen from the foregoing remarks that to obtain the best results from records it is necessary to consider the size of sapphire to be used, these varying with the nature of the cut of the record, i.e. number of threads to the inch, it being remembered always that too large a point will give unsatisfactory reproductions, and in the case of wax records will quickly wear down the walls of the grooves, whilst a smaller sapphire than is really necessary will always give a faithful reproduction, though with decreased volume. In the case of wax records, however, too small a sapphire will quickly cut them up. As I have already stated, to get the best results from any type of record use the style of sapphire supplied by the manufacturers of the particular records in question and you will be on the safe side. In the case of phono-cut discs this means having several sizes of sapphire-mounted needles, whilst for wax records the four-minute and two-minute repro. points are required, and for indestructible cylinders the peculiar type supplied by Messrs. Murdoch with their extra tension reproducer. Whilst on the subject of the phono. disc reproduction I should like to mention for the benefit of experimenters and mechanics who try their hand at making repros., etc., that in my opinion there is at present nothing to equal the Pathe "Majestic" sound-box for the playing of these records. The following particulars will perhaps be of interest to them:— Diaphragm, 2½ in. diameter; weight of sound-box, 8 oz.; ratio of the arms of the stylus bar, 1 : ; angle of sapphire holder to the plane of the record, about 45 degs. After playing a Pathe disc with one of these "Majestic" sound-boxes the reproduction through their ordinary "Ebonite" model seems quite tubby and muffled in comparison. It will be noticed that the weight of the sound-box is 8 oz., which seems rather excessive, and in this connection I cannot help thinking that either the sapphire or the record must eventually suffer, and I should think that an

ounce or two might be taken off without greatly deteriorating the quality of the reproduction. Undoubtedly the size of the diaphragm necessitates having a fairly heavy tension on it when reproducing to obviate the tubbiness and fogginess previously mentioned. If making a repro. on these lines I think it would be advisable to insulate the whole of the sound-box itself by mounting the bridge carrying the lever on rubber washers, and instead of using screws to secure the bridge to the rim of the sound-box, which would defeat the object in view, to fix same by small clamps lined with rubber. By doing this there is no metallic connection whatever between the sapphire holder and the sound-box, i.e. of course provided the diaphragm does not touch the shell of the sound-box at any point. The sound-box itself can, of course, be insulated by rubber from the tone-arm in the usual way, as a double precaution. You need not expect any remarkable results from following this course, but at the same time you will be able to feel that should the reproduction be faulty in any way it is not for want of proper insulation. When I say use rubber I mean the genuine article — selling at the present time in the rough at about 6s. per lb. — and not the imitation kind, which gets much too hard if under slight pressure for any length of time, and consequently useless for insulation purposes. To anyone with a mechanical twist it would not be very difficult to mount various sized sapphires on the periphery of a small metal disc, something like a star, the latter being made to revolve by loosening a small thumbscrew or fly-nut, and thus bring whichever size is required to be used readily in position for playing. Owing to the high quality the various sapphire discs have now reached, if any dissatisfaction should be felt when playing them, it will probably be found that they are being reproduced with a wrong-sized sapphire, and in this connection it is well to bear in mind that with this type of disc it is necessary "to cut your sapphire according to your record."

continued overleaf

The above article, which was published in January 1911, was found for us by Frank Andrews, who points out that the surface coating of the first Neophone discs was, in fact, enamel rather than celluloid. He also comments that the two patents for Nicole Records, as far as he remembers, involved the facing of a plasticised material with another, smoother, plasticised material. However, my own recollection of the core of a Nicole record is that it bears an uncanny resemblance to cardboard. Possibly the facing was attached to it when it was still in the form of pulp – which would, after all, be a sort of coarse plasticised material.

THE HILLANDALE NEWS is published by THE CITY OF LONDON PHONOGRAPH AND GRAMOPHONE SOCIETY.

Editorial address: The Hoo, Hook Green, Meopham, Gravesend, Kent.

President: George Frow, [REDACTED] Sevenoaks, Kent, TN13 3SH

Vice-Presidents: James F. Dennis, R.C.S.,

A.D. Besford

Chairman/Editor: Christopher Proudfoot, [REDACTED] Meopham, Gravesend, Kent.

Vice-Chairman: D.R. Roberts, [REDACTED] Pyrford, Woking, Surrey GU22 8TN.

Hon. Treasurer: B.A. Williamson, [REDACTED] Liverpool, L16 1LA.

Hon. Secretary: John McKeown, [REDACTED] St. James's, London, SW1Y 6PZ.

Archivist: John Carreck, [REDACTED] Chislehurst, Kent, BR7 5DX.

Hon. Members: Ernie Bayly, Dennis Harbur, George Frow, Len Watts.

Committee: B. Raynaud, F. Andrews, Len Watts.

TREASURER'S NOTES: In future, would members please send all monies in Sterling (cheques, Postal Orders, etc.) direct to the Treasurer, *together with all orders for goods*, as this will simplify our accounting system, and avoid double handling.

MEMBERSHIP RATES:

U.K. & Europe

£4.00 per year

U.S.A. & Canada

\$8.00 Surface Mail

New Zealand Airmail

£5.00 per year

\$10.00 Airmail

Australia, Japan, etc. (now payable directly to the Treasurer, as bulk subscription has ceased)

£5.00 per year

Overseas members are requested to send **STERLING DRAFTS** or banknotes, as check clearances here carry a high commission rate. The Society no longer operates within the Post Office Giro system. New Zealand and Australian Postal Orders are acceptable in the U.K. To save postage in mailing receipts, these are sent out with the goods or next magazine to members. **PLEASE MAKE OUT ALL CHECKS AND DRAFTS PAYABLE TO "THE CITY OF LONDON PHONOGRAPH AND GRAMOPHONE SOCIETY"**.

HEREFORD. Details from the Secretary, D.G. Watson, [REDACTED] Tupsley, Hereford.

MIDLANDS. Details from the Secretary, P. Bennett, [REDACTED] Goldthorn Park, Wolverhampton, Staffs, WV4 5DE. Phone: [REDACTED]

MANCHESTER. Details from the Secretary, Ernest Wild, [REDACTED] Uppermill, Oldham OL3 6EB

VICTORIA, AUSTRALIA. Details from C. Gracie, [REDACTED] Cavendish, Victoria 3408, Australia.

MEMBERS PLEASE NOTE that all money should now be sent to our Treasurer, B.A. Williamson, [REDACTED] [REDACTED] Liverpool, L16 1LA.

Printed by Flo-Print, Langton Green, Tunbridge Wells Kent Telephone: Langton 3388 (STD Code 0892 86)